

Problems #1-10: Identify the best answer from the given choices. Place the letter on the answer line.

1) Select the correct graph of $x \leq -5$

A.

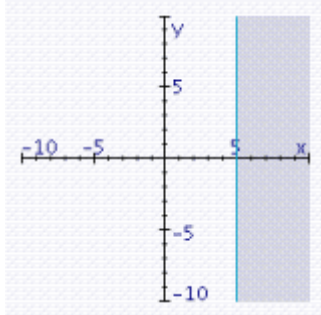

B.

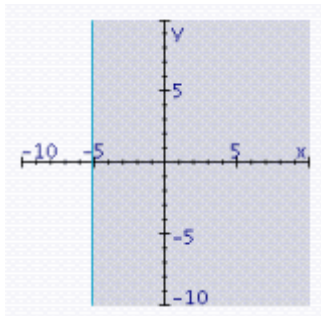

C.

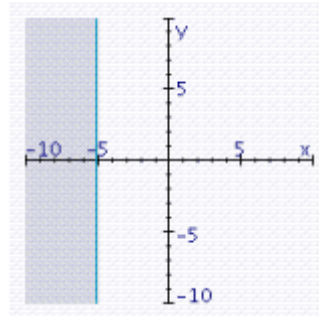

D.

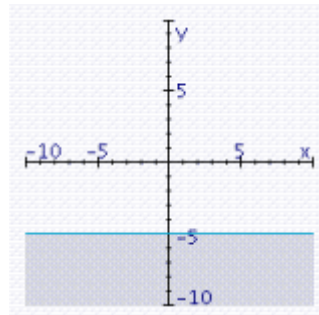

E.

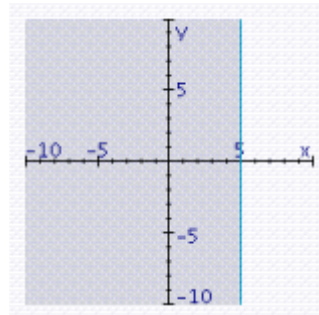

Answer to #1 _____

2) Which inequality does the graph satisfy?

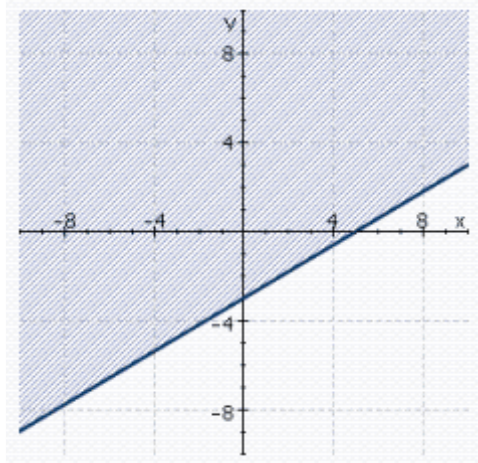

- A. $5x - 3y \leq 15$
- B. $3x - 5y \leq 15$
- C. $5x - 3y \geq 15$
- D. $-3x - 5y \leq 15$
- E. $3x - 5y \geq 15$

Answer to #2 _____

3) Find the maximum value of $F = -30x + 50y$ in the feasible region shown below.

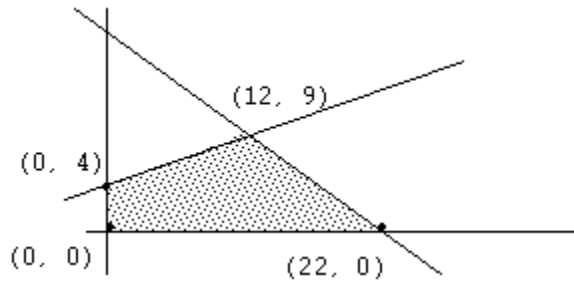

- A. 1100
- B. 90
- C. 660
- D. 200
- E. 330

Answer to #3 _____

4) Select the point which is in the feasible region of the system of inequalities.

$$\begin{aligned}
 4x + y &\leq 8 \\
 2x + 5y &\leq 18 \\
 x &\geq 0 \\
 y &\geq 0
 \end{aligned}$$

- A. (2, 4)
- B. (1, 3)
- C. (-1, 2)
- D. (4, 1)
- E. (0, 5)

Answer to #4 _____

5) Which point is NOT a corner point of the feasible region of the following system of inequalities?

$$\begin{aligned}
 4x + 3y &\leq 15 \\
 x + 6y &\leq 9 \\
 x &\geq 0 \\
 y &\geq 0
 \end{aligned}$$

- A. (0, 5)
- B. (3, 1)
- C. (3.75, 0)
- D. (0, 0)
- E. (0, 1.5)

Answer to #5 _____

6) Select the correct graph of the given system of inequalities and indicate whether the solution set is bounded or unbounded.

$$8x + 5y \leq 40$$

$$6x + y \geq 8$$

$$x + y \geq 3$$

$$x \geq 0$$

$$y \geq 0$$

A. Unbounded

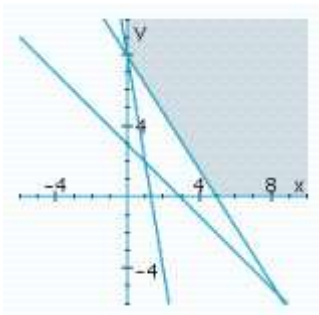

B. Bounded

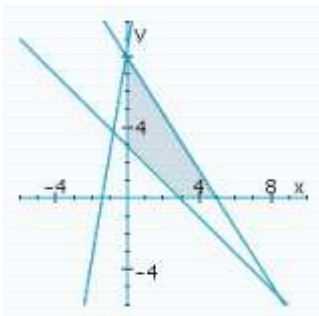

C. Bounded

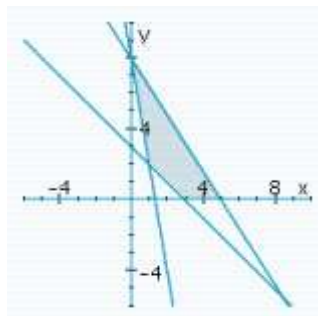

D. Bounded

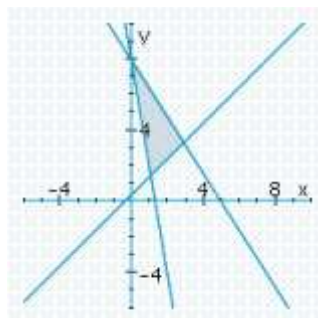

E. Unbounded

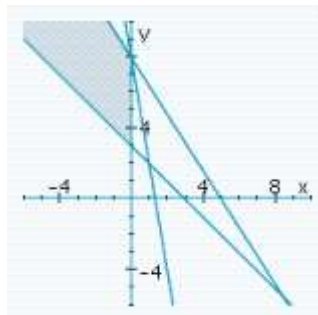

Answer to #6 _____

7) Solve the linear programming problem

Maximize $F = 8x + 2y$

Subject to $x + y \leq 4$

$$2x + y \leq 5$$

$$x \geq 0$$

$$y \geq 0$$

A. Max of 20 at (2.5, 0)

B. Max of 28 at (2.5, 4)

C. Max of 10 at (0, 5)

D. Max of 14 at (1, 3)

E. Max of 8 at (0, 4)

Answer to #7 _____

8) Solve the linear programming problem

Minimize $C = -3x + y$

Subject to $x + 3y \leq 9$

$4x + 3y \leq 12$

$x \geq 0$

$y \geq 0$

- A. Min of 3 at (0, 3)
- B. Min of 0 at (0, 0)
- C. Min of -10 at (4, 2)
- D. Min of -9 at (3, 0)
- E. Min of -12 at (4, 0)

Answer to #8 _____

9) A tailor has 80 yards of cotton material and 120 yards of woolen material. A suit requires two yards of cotton and one yard of wool. A dress requires one yard of cotton and three yards of wool. A suit sells for \$30 and a dress sells for \$20. Let $x = \#$ of suits made and $y = \#$ of dresses made. If the goal is to maximize income, which of the following inequalities is a constraint to this linear programming problem?

- A. $3x + y \geq 120$
- B. $2x + y \geq 80$
- C. $x + 2y \leq 80$
- D. $x + 2y \geq 120$
- E. $x + 3y \leq 120$
- F. $3x + y \leq 80$

Answer to #9 _____

10) The maximum daily production of an oil refinery is 1400 barrels. The refinery can produce two types of fuel: gasoline and heating oil. The production cost per barrel is \$6 for gasoline and \$8 for heating oil. The daily production budget is \$9600. The profit is \$3.50 per barrel on gasoline and \$4 per barrel on heating oil. What is the maximum total profit, given these constraints?

- A. \$4800
- B. \$4900
- C. \$5000
- D. \$5200
- E. \$5300

Answer to #10 _____

#11-16: Show all your work.

11) Find the minimum and maximum values of $F = 8x - 3y$ in the feasible region shown below.

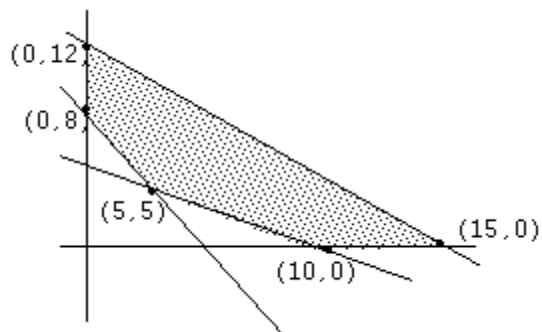

Max value of _____ at $x =$ _____, $y =$ _____

Min value of _____ at $x =$ _____, $y =$ _____

12) Graph the following system of linear inequalities and shade the feasible region. Is it bounded or unbounded? Find the coordinates of all corner points. Show all your work.

$$2x + y \geq 6$$

$$x - y \leq 3$$

$$x - y \geq -5$$

$$x \leq 5$$

Corner points at (write as ordered pairs):

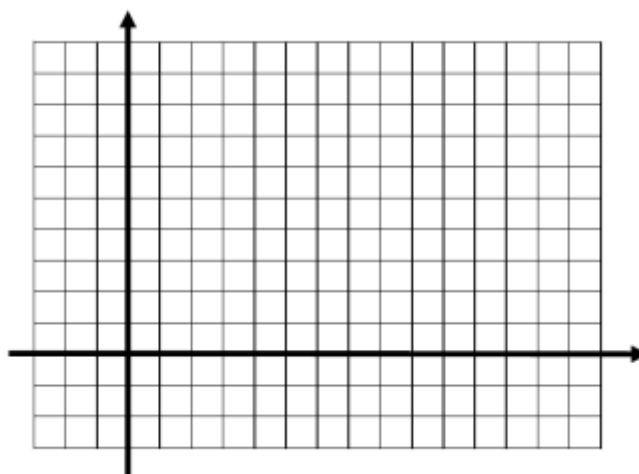

Circle: Feasible region is bounded / unbounded

13) Find the minimum value of $C = 28x + 14y$ and the point at which it occurs. Be sure to shade the feasible region on the graph below. Show all your work.

$$5x + 2y \geq 10$$

$$4x + 3y \geq 12$$

$$x \geq 0$$

$$y \geq 0$$

Corner points at (write as ordered pairs):

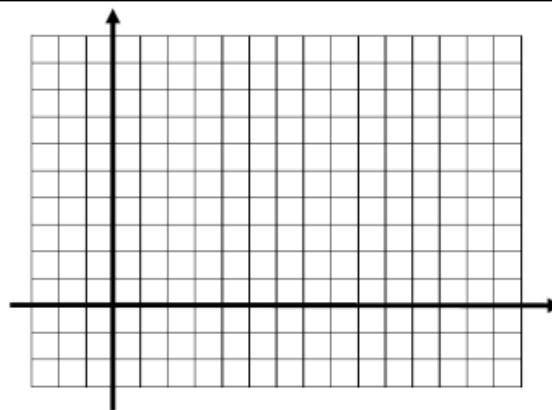

There is a minimum value of _____ at $x =$ _____ , $y =$ _____

14) Find the maximum and minimum values of $F = -11x - 23y$ and the points at which they occur. Be sure to shade the feasible region on the graph below. Show all your work.

$$x + 4y \leq 8$$

$$5x + 4y \leq 20$$

$$x \geq 0$$

$$y \geq 0$$

Corner points at (write as ordered pairs):

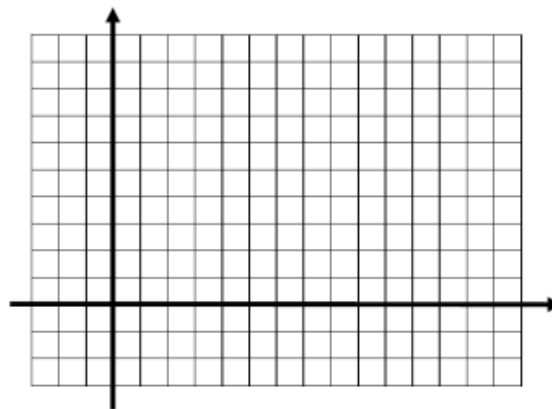

There is a maximum value of _____ at $x =$ _____ , $y =$ _____

There is a minimum value of _____ at $x =$ _____ , $y =$ _____

15) An airline with two types of airplanes, x and y , has contracted with a tour group to provide accommodation for a minimum of each of 2800 first-class, 2000 tourist, and 5600 economy-class passengers. Airplane x costs \$15000 to operate and can accommodate 40 first-class, 40 tourist, and 20 economy-class passengers, while airplane y costs \$12000 to operate and can accommodate 20 first-class, 10 tourist, and 70 economy-class passengers. If the goal is to find the number of each type to minimize operating costs, write the objective function and ALL constraints for this linear programming problem (i.e. **SET UP BUT DO NOT SOLVE**).

Minimize: Cost = _____

Subject to the following constraints:

16) Suppose a horse feed to be mixed from soybean meal and oats must contain at least 200 lb of protein and 40 lb of fat. Each sack of soybean meal costs \$55 and contains 60 lb of protein and 10 lb of fat. Each sack of oats costs \$25 and contains 20 lb of protein and 5 lb of fat.

- (a) How many sacks of each should be used to minimize cost?
- (b) What is the minimum cost?

Answer 16a: _____

Answer 16b: _____