

# Root Statistics of Random Polynomials with Bounded Mahler Measure

CHRISTOPHER D. SINCLAIR and MAXIM L. YATTSELEV

October 21, 2014

## Abstract

The Mahler measure of a polynomial is a measure of complexity formed by taking the modulus of the leading coefficient times the modulus of the product of its roots outside the unit circle. The roots of a real degree  $N$  polynomial chosen uniformly from the set of polynomials of Mahler measure at most 1 yields a Pfaffian point process on the complex plane. When  $N$  is large, with probability tending to 1, the roots tend to the unit circle, and we investigate the asymptotics of the scaled kernel in a neighborhood of a point on the unit circle. When this point is away from the real axis (on which there is a positive probability of finding a root) the scaled process degenerates to a determinantal point process with the same local statistics (*i.e.* scalar kernel) as the limiting process formed from the roots of complex polynomials chosen uniformly from the set of polynomials of Mahler measure at most 1. Three new matrix kernels appear in a neighborhood of  $\pm 1$  which encode information about the correlations between real roots, between complex roots and between real and complex roots. Away from the unit circle, the kernels converge to new limiting kernels, which imply among other things that the expected number of roots in any open subset of  $\mathbb{C}$  disjoint from the unit circle converges to a positive number. We also give ensembles with identical statistics drawn from two-dimensional electrostatics with potential theoretic weights, and normal matrices chosen with regard to their topological entropy as actions on Euclidean space.

**Keywords:** Pfaffian point process, Mahler measure, random polynomial, eigenvalue statistics, skew-orthogonal polynomials, matrix kernel.

**MSC2010:** 15B52, 11C08, 11G50, 82B21, 60G55, 33C15, 42C05.

## Contents

<b>1</b>	<b>Introduction</b>	<b>2</b>
1.1	Mahler measure	5
1.2	Volumes of Star Bodies	6
1.3	The Joint Density of Roots	8
1.4	Pfaffian Point Processes	10
1.5	Scaling Limits	13
1.6	Notation	15
1.7	The Mahler Ensemble of Complex Polynomials	15

<b>2</b>	<b>Main Results</b>	<b>17</b>
2.1	The Expected Number of Real Roots . . . . .	17
2.2	Kernel Limits Near the Unit Circle . . . . .	17
2.3	Kernel Limits Away from the Unit Circle . . . . .	20
<b>3</b>	<b>Other Ensembles with the Same Statistics</b>	<b>22</b>
3.1	An Electrostatic Model . . . . .	22
3.2	A Normal Matrix Model . . . . .	24
<b>4</b>	<b>Matrix Kernels and Skew-Orthogonal Polynomials</b>	<b>24</b>
<b>5</b>	<b>A Family of Polynomials</b>	<b>27</b>
5.1	Algebraic Properties of the Polynomials . . . . .	27
5.2	Asymptotic Properties of the Polynomials . . . . .	28
5.3	Asymptotic Properties of the Sums away from the Unit Circle . . . . .	29
5.4	Asymptotic Properties of the Sums on the Unit Circle . . . . .	30
<b>6</b>	<b>Proofs</b>	<b>31</b>
6.1	Proof of Theorem 4.3 . . . . .	31
6.2	Proofs of Propositions 5.1—5.3 . . . . .	33
6.3	Proofs of Theorem 5.4 and Proposition 5.6 . . . . .	36
6.4	Proof of Theorem 5.7 . . . . .	38
6.5	Proofs of Theorems 5.8 & 5.9 . . . . .	40
6.6	Proofs of Theorems 2.2—2.5 . . . . .	44
6.7	Proofs of Theorems 2.7—2.9 . . . . .	51
6.8	Proof of Theorem 2.1 . . . . .	57
<b>7</b>	<b>Acknowledgments</b>	<b>64</b>
<b>A</b>	<b>Random Normal Matrices</b>	<b>65</b>
A.1	The Spectral Parametrization and the Induced Measure on Eigenvalues . . . . .	66
A.1.1	Complex Normal Matrices . . . . .	66
A.1.2	Real Normal Matrices . . . . .	68
A.2	The Induced Measure on Eigenvalues . . . . .	69

## 1 Introduction

The study of roots of random polynomials is an old subject extending back at least as far as the early 1930s. Several early results revolve around estimating, as a function of degree  $N$ , the number of real roots of polynomials with variously proscribed integer or real coefficients. These begin with Bloch and Pólya, who gave bounds for the maximum number of real roots of polynomials with coefficients in  $\{-1, 0, 1\}$  (their lower bound for this maximum being  $O(N^{1/4}/\sqrt{\log N})$ ) and showed that the expected number of real roots does not exceed  $O(\sqrt{N})$  [3]. Shortly thereafter, Littlewood and Offord proposed the same sort of questions, but for polynomials with independent standard normal coefficients, and for coefficients chosen uniformly from  $[-1, 1]$  or  $\{-1, 1\}$ . They proved that the expected number of real roots in these cases is eventually bounded by  $25(\log N)^2 + 12 \log N$ , but were unable to determine if this bound was of the right order [24, 25]. In the 1940s, Kac

determined not only the correct asymptotic ( $2 \log N/\pi$ ) for the expected number of real roots in the i.i.d. normal case, but in fact gave, for each fixed  $N$ , an explicit function when integrated over an interval gives the expected number of real roots in that interval [19]. (Such a function is called an *intensity* or *correlation function*, and will be central in the present work). Kac later extended his results for coefficients which are (arbitrary) i.i.d. continuous random variables with unit variance [20] (in particular the asymptotic estimate remains unchanged in this situation). Since then, many results on the expected number of real roots of random polynomials have been presented for various meanings of the word ‘random’; of particular note are [12], [10] and [7].

An obvious question beyond ‘how many roots of a random polynomial are real?’ is ‘where do we expect to find the roots of a random polynomial?’. Certainly, knowing that some expected number of roots are real gives some information about where we expect to find them. Moreover, Kac’s formula for the intensity, when applicable, gives detailed information about where the real roots are expected to reside. In the 1990s Shepp and Vanderbei extended Kac’s intensity result to the complex roots of random polynomials with i.i.d. real coefficients by producing a complimentary intensity supported on  $\mathbb{C} \setminus \mathbb{R}$  [33]. This together with Kac’s intensity specifies the spatial density of roots of random Gaussian complex polynomials, and in particular shows that such roots have a tendency, when  $N$  is large, to clump near the unit circle. Some part of this observation was made much earlier—the early 1950s—by Erdős and Turán, who prove (in their own paraphrasing)

... that the roots of a polynomial are uniformly distributed in the different angles with vertex at the origin if the coefficients “in the middle” are not too large compared with the extreme ones [11].

Strictly speaking, the result of Erdős and Turán is not a result about random polynomials, but rather gives an upper bound, as a function of the coefficients of the polynomials, for the difference between the number of roots in an angular segment of a polynomial from the number assuming radial equidistribution. This can be translated into a result about random polynomials given information about the distribution of coefficients.

Erdős and Turán’s result presaged the fact that for many types of random polynomials, the zeros have a tendency to be close to uniformly distributed on the unit circle, at least when the degree is large. One way of quantifying this accumulation is to form a probability measure from a random polynomial by placing equal point mass at each of its roots. This measure is sometimes called the *empirical* measure, and given a sequence of polynomials of increasing degree we can ask whether or not the resulting sequence of empirical measure weak-\* converges (or perhaps in some other manner) to uniform measure on the unit circle (or perhaps some other measure). Given a random sequence of such polynomials we can then investigate in what probabilistic manner (almost surely, in probability, etc.) this convergence occurs, if it occurs at all. Another way of encoding convergence of roots to the unit circle (or some other region) can be given by convergence of intensity/correlation functions (assuming such functions exist). For Gaussian polynomials this convergence of intensity functions appears in the work of Shepp and Vanderbei, and was later extended to i.i.d. coefficients from other stable distributions (and distributions in their domain of attraction) by Ibragimov and Zeitouni in [18]. For more general conditions which imply convergence of roots to the unit circle, see the recent work of Hughes and Nikeghbali [?].

The random polynomials we consider here will *not* have i.i.d. coefficients—a situation first considered rigorously in generality by Hammersley [16]. Our polynomials will be selected uniformly from a certain compact subset of  $\mathbb{R}^{N+1}$  (or  $\mathbb{R}^N$ ) as identified with coefficient

vectors of degree  $N$  polynomials (or monic degree  $N$  polynomials). Specifically we will be concerned with polynomials chosen uniformly from the set with Mahler measure at most 1. Definitions will follow, but for now we define the Mahler measure of a polynomial to be the absolute value of the leading coefficient times the modulus of the product of the roots outside the unit circle<sup>1</sup>. The set of coefficient vectors of degree  $N$  polynomials with Mahler measure at most 1, which we denote for the moment by  $B^{(N)}$ , is a compact subset of  $\mathbb{R}^{N+1}$ , and we will primarily be concerned with the roots of polynomials and monic polynomials chosen uniformly from this region, especially in the limit as  $N \rightarrow \infty$ . We remark that Mahler measure is homogeneous, and thus the set of polynomials with Mahler measure bounded by  $T > 0$  is a dilation (or contraction) of  $B^{(N)}$ . That is, whether one chooses uniformly from the set of Mahler measure at most 1 or  $T$ , the distribution of roots is the same. (This latter fact is *not* true for monic polynomials).

The choice of this region is not arbitrary; Mahler measure is an important *height*, or measure of complexity, of polynomials, and appears frequently in the study of integer polynomials and algebraic numbers. Of particular note in this regard (a result of Kronecker, though not phrased in this manner) is that the set of integer polynomials with Mahler measure equal to 1 is exactly equal to the product of monomials and cyclotomic polynomials; that is an integer polynomial with Mahler measure 1 has all roots in  $\mathbb{T} \cup \{0\}$  where  $\mathbb{T}$  is the unit circle [21]. An unresolved problem, posed by D.H. Lehmer in 1933, is to determine whether or not 1 is a non-isolated point in the range of Mahler measure restricted to integer polynomials<sup>2</sup> [23]. On one hand, this is a question about how the sets  $B^{(N)}$  are positioned relative to the integer lattices  $\mathbb{Z}^N$ —in particular if we denote by  $r_N > 1$  the smallest number such that the dilated star body  $r_N B^{(N)}$  contains an integer polynomial with a non-cyclotomic factor, Lehmer’s question reduces to whether or not  $r_N \rightarrow 1$ . On the other hand, since Mahler measure is a function of the roots of a polynomial, Lehmer’s problem can be translated as a question about how quickly the roots of a sequence of non-cyclotomic polynomials can approach the unit circle.

One motivation for studying the roots of polynomials chosen uniformly from  $B^{(N)}$  is that such results might suggest analogous results for integer polynomials with small Mahler measure. Lehmer’s problem has been resolved for various classes of polynomials, for instance a sharp lower bound for the Mahler measure of non-cyclotomic polynomials with all real roots has been given by Schinzel [?], and a sharp lower bound for non-cyclotomic, non-reciprocal polynomial was given by Smyth [?]; both of these results appeared in the early 1970s, and reflect the fact that polynomials with small Mahler measure have roots which are in some manner constrained. Along these lines, a result of Langevin from the 1980s says that, the roots of a sequence of irreducible integer polynomials with unbounded degree and bounded Mahler measure cannot avoid any open set in  $\mathbb{C}$  which contains a point on the unit circle [?]. In fact, the result is stronger: any sequence of irreducible integer polynomials with unbounded degree whose roots avoid such a set have Mahler measure which grows exponentially with the degree. A more recent result of Bilu, and one which is similar in spirit to that of Erdős and Turán, states that the empirical measures of any sequence of irreducible, integer polynomials with increasing degree and Mahler measure tending to 1 converges weak-\* to uniform measure on the unit circle [2].

<sup>1</sup>It goes without saying that Mahler measure is not a measure in the sense of integration theory. Perhaps a better name would be ‘Mahler height’ but that ship has already sailed.

<sup>2</sup>The current reigning champion non-cyclotomic polynomial with smallest Mahler measure is  $z^{10} + z^9 - z^7 - z^6 - z^5 - z^4 - z^3 + z + 1$  and has Mahler measure  $\approx 1.18$ . Remarkably, this polynomial was discovered by Lehmer in 1933, and has survived the advent of computers.

Another motivation for studying the roots of polynomials chosen uniformly from  $B^{(N)}$  comes from random matrix theory. Indeed, the results presented here will be familiar, in form at least, to results about the eigenvalues of random matrices. It is beyond the scope of the current work to present a survey of random matrix theory (see however the collection [1] for a glimpse into the current state of random matrix theory and its applications). We will, however, underscore two major themes here. The first is, for certain very well-behaved ensembles<sup>3</sup> of random matrices, the intensity/correlation functions are expressible in terms of determinants or Pfaffians of matrices formed from a single object—a *kernel*. Pioneering work on such *determinantal* and *Pfaffian* ensembles was done in the 1960s and 1970s by Mehta [28, 30, 29], Gaudin [30, 15] and Dyson [8, 9]. For these ensembles, this kernel depends on the size of the matrices, and the limiting eigenvalue statistics can be determined from the limit of this kernel in various scaling regimes. The scaled limits of these kernels yield *limiting, local* eigenvalue statistics on scales where the eigenvalues have some prescribed spacing or density. We will find that our ensemble of random polynomials has such a kernel (of the Pfaffian form) and will present the scaling limits of this kernel here.

A second major theme in random matrix theory is that of *universality*. Loosely stated, universality says that the limiting, local statistics of eigenvalues of ensembles of random matrices fall into one of a handful of *universality classes*<sup>4</sup> based on large scale structure (for instance symmetries on the entries which may geometrically constrain the position of eigenvalues) but largely independent of the actual distribution on the matrices. (See Kuijlaars’ essay [22] for a more precise definition of universality). Thus, a universality class is akin to the basin of attraction for stable distributions.

Universality is important in combination with the identification of ensembles whose limiting local statistics are well understood. Such ensembles, for instance those which have kernels whose scaling limits are explicitly described, play the role of stable distributions, in the sense that they provide prototypes for their universality class. We will present an ensemble of random matrices whose eigenvalue statistics are identical to those of the roots of polynomials chosen at random from  $B^{(N)}$ . Thus, the results here have repercussion beyond just the study of the statistics of roots of polynomials with bounded Mahler measure, but also as a prototypical ensemble in a newly discovered universality class.

## 1.1 Mahler measure

The Mahler measure of a polynomial  $f(z) \in \mathbb{C}[z]$  is given by

$$M(f) = \exp \left\{ \int_0^1 \log |f(e^{2\pi i\theta})| d\theta \right\}.$$

By Jensen’s formula, if  $f$  factors as  $f(z) = a \prod_{n=1}^N (z - \alpha_n)$ , then

$$M(f) = |a| \prod_{n=1}^N \max \{1, |\alpha_n|\}. \tag{1.1}$$

<sup>3</sup>*Ensemble* is physics parlance for a probability space.

<sup>4</sup>We are being woefully imprecise here. For instance, Lubinsky [26] showed that each reproducing kernel of a de Branges space gives rise to a universality class that may arise in the bulk (that is, in the limiting support of eigenvalues) for some unitary ensemble; however, he also showed [27] that in measure in the bulk it is always the universality class of the “sine kernel”.

Mahler measure is not a measure in the sense of measure theory, but an example of a height—a measure of complexity—of polynomials, and is of primary interest when restricted to polynomials with integer (or other arithmetically defined) coefficients.

In [6], Vaaler and Chern compute the volume (Lebesgue measure) of the set of real degree  $N$  polynomials (as identified with a subset of  $\mathbb{R}^{N+1}$  via their coefficient vectors). This volume arises in the main term for the asymptotic estimate for the number of integer polynomials of degree  $N$  with Mahler measure bounded by  $T$  as  $T \rightarrow \infty$ . Amazingly, Chern and Vaaler’s calculation showed that this volume was a rational number with a simple product description for each  $N$ . A similar simple expression was found for the related volume of monic polynomials.

The first author in [35] gave a Pfaffian formulation for Chern and Vaaler’s product formulation, which was later shown to be related to a normalization constant for an ensemble of random matrices in [34].

The purpose of this article is to explore the statistics of zeros of polynomials chosen at random from Chern and Vaaler’s volumes, especially in the limit as  $N \rightarrow \infty$  in an appropriate scaling regime. In fact, we will look at a natural one-parameter family of ensembles of random polynomials which interpolate between the volumes of monic and non-monic polynomials considered by Chern and Vaaler.

We will also introduce ensembles of random matrices and a two-dimensional electrostatic model which have the same statistics as our ensembles of random polynomials.

## 1.2 Volumes of Star Bodies

Mahler measure is an example of a distance function in the sense of the geometry of numbers, and therefore, when restricted to coefficient vectors of degree  $N$  polynomials satisfies all the axioms of a vector norm except the triangle inequality. Specifically,  $M$  is continuous, positive definite and homogeneous:  $M(cf) = |c|M(f)$ . We will generalize the situation slightly by introducing a parameter  $\lambda \geq 0$  and define the  $\lambda$ -homogeneous Mahler measure by

$$M_\lambda \left( a \prod_{n=1}^N (z - \alpha_n) \right) = |a|^\lambda \prod_{n=1}^N \max \{1, |\alpha_n|\}. \quad (1.2)$$

Generalizing in this manner,  $M_\lambda$  is no longer continuous as a function of coefficient vectors (except when  $\lambda = 1$ ) however, as we shall see, the parameter  $\lambda$  will appear naturally in our subsequent calculations.

The ‘unit-ball’ of  $M$  is not convex, but rather is a symmetric star body. We define this set as

$$B_\lambda = \left\{ \mathbf{a} \in \mathbb{R}^{N+1} : M_\lambda \left( \sum_{n=0}^N a_n z^n \right) \leq 1 \right\},$$

and we define the star body of radius  $T > 0$  by  $B_\lambda(T) = T^{1/\lambda} B_\lambda$ . We also define the related sets of monic polynomials given by  $\tilde{B} = \tilde{B}(1)$  where

$$\tilde{B}(T) = \left\{ \mathbf{b} \in \mathbb{R}^N : M_\lambda \left( z^N + \sum_{n=0}^{N-1} b_n z^n \right) \leq T \right\}.$$

Note that, when restricted to monic polynomials,  $M_\lambda = M$ , and  $\tilde{B}$  corresponds to the set of monic degree  $N$  real polynomials with all roots in the closed unit disk. We remark that

$B_\lambda$  and  $\tilde{B}$  are rather complicated geometrically. For instance, note that both  $(z - 1)^N$  and  $z^N - 1$  lie in  $\tilde{B}$  while  $(z^{N-10} - 1)(z^{10} + z^9 - z^7 - z^6 - z^5 - z^4 - z^3 + z + 1)$  is *not* in  $\tilde{B}$ . That is,  $\tilde{B}$  contains both points of large and small 2-norm ( $2^{N/2}$  and  $\sqrt{2}$ , respectively), but there also exist integer points of relatively small norm which are not in  $\tilde{B}$ .

For the convenience of the next calculation, we shall write  $M_\lambda(c, \mathbf{b})$  and  $\tilde{M}(\mathbf{b})$  for

$$M_\lambda(c, \mathbf{b}) = M_\lambda \left( cz^N + \sum_{n=0}^{N-1} b_n z^n \right)$$

and

$$\tilde{M}(\mathbf{b}) = M_\lambda(1, \mathbf{b}) = M_\lambda \left( z^N + \sum_{n=0}^{N-1} b_n z^n \right).$$

The second of these functions, we shall call the *monic* Mahler measure (and is obviously independent of  $\lambda$ ).

The following manipulations are elementary, but of central importance in Chern and Vaaler's determination of the volume of  $B_\lambda$  and  $\tilde{B}$ , and in our analysis of the statistics of roots of polynomials chosen uniformly from these sets. By volume, we shall of course mean Lebesgue measure.

$$\begin{aligned} \text{vol } B_\lambda &= \int_{-\infty}^{\infty} \text{vol} \{ \mathbf{b} : M_\lambda(c, \mathbf{b}) \leq 1 \} \, dc \\ &= \int_{-\infty}^{\infty} \text{vol} \{ c\mathbf{b} : M_\lambda(c, c\mathbf{b}) \leq 1 \} \, dc \\ &= 2 \int_0^{\infty} c^N \text{vol} \{ \mathbf{b} : \tilde{M}(\mathbf{b}) \leq c^{-\lambda} \} \, dc, \end{aligned}$$

where at this last step we have used the  $\lambda$ -homogeneity of  $M_\lambda$ . The change of variables  $\xi = c^{-\lambda}$  gives

$$\text{vol } B_\lambda = \frac{2}{\lambda} \int_0^{\infty} \xi^{-(N+1)/\lambda} \text{vol} \{ \mathbf{b} : \tilde{M}(\mathbf{b}) \leq \xi \} \frac{d\xi}{\xi}.$$

If we denote the distribution function of  $\tilde{M}$  by  $f_N(\xi) := \text{vol } \tilde{B}(\xi)$ , then

$$\text{vol } B_\lambda = \frac{2}{\lambda} \int_0^{\infty} \xi^{-s-1} f_N(\xi) \, d\xi, \quad s = \frac{N+1}{\lambda}. \tag{1.3}$$

The astute reader will notice the appearance of the Mellin transform of  $f_N$  appearing in this expression for the volume of  $B_\lambda$ . Interpreting the integral in (1.3) as a Lebesgue-Stieltjes integral we can apply integration by parts to find

$$\text{vol } B_\lambda = \frac{2}{N+1} F(s), \quad F(s) = \int_{\mathbb{R}^N} \tilde{M}(\mathbf{b})^{-s} \, d\mu_{\mathbb{R}}^N(\mathbf{b}),$$

where  $\mu_{\mathbb{R}}$  is Lebesgue measure on  $\mathbb{R}$  and  $\mu_{\mathbb{R}}^N$  the resulting product measure on  $\mathbb{R}^N$ . Clearly, also the volume of the set of monic polynomials with Mahler measure at most 1 is given by

$$\text{vol } \tilde{B} = \lim_{s \rightarrow \infty} F(s).$$

By a random polynomial we shall mean a polynomial chosen with respect to the density  $M(\mathbf{b})^{-s}/F(s)$ , where we view  $s$  as a parameter. The goal of this paper is to explore the statistics of roots of random polynomials in the limit as  $N \rightarrow \infty$  and  $(N+1)/s \rightarrow \lambda$ . This is equivalent to studying the statistics of zeros of polynomials chosen uniformly from  $B_\lambda$  as the degree goes to  $\infty$ .

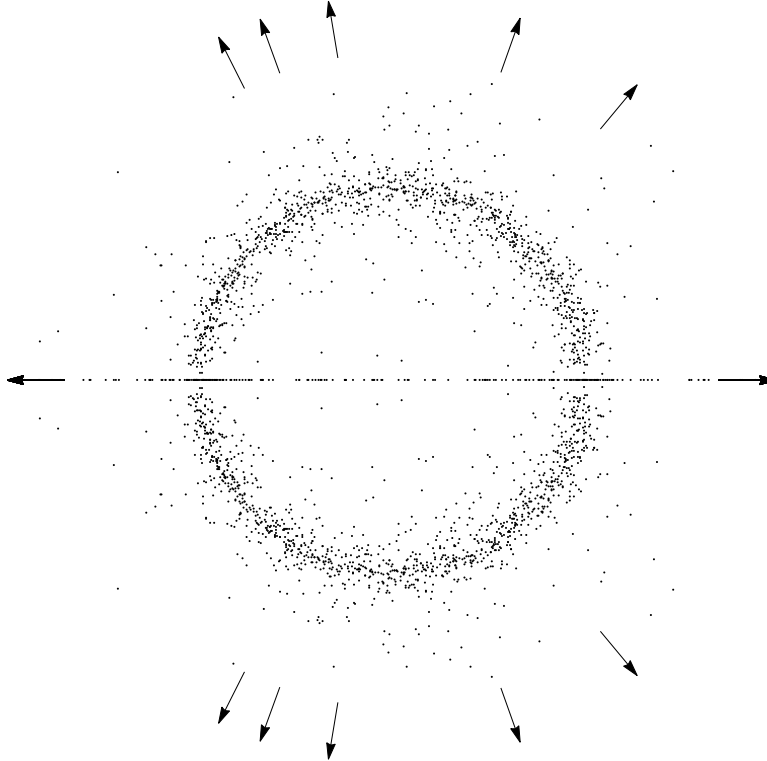

Figure 1: A simultaneous plot of the roots of 100 random polynomials of degree 28 corresponding to  $\lambda = 1$ . Note that, since we are sampling uniformly from a region in  $\mathbb{R}^N$ , the complicated geometric nature of  $\tilde{B}$  makes it difficult to accurately sample a truly (pseudo) random polynomial. This example was achieved by doing (for each polynomial) a ball-walk of 10,000 steps of length .01 starting from  $x^{28}$ . The arrows indicate directions of outlying roots.

### 1.3 The Joint Density of Roots

Since the coefficients of our random polynomials are real, the roots are either real or come in complex conjugate pairs; that is we may identify the set of roots of degree  $N$  polynomials with

$$\bigcup_{\substack{(L,M) \\ L+2M=N}} \mathbb{R}^L \times \mathbb{C}^M.$$



In the context of our random polynomials  $L$  and  $M$  are integer valued random variables representing the number of real and complex conjugate pairs of roots respectively. The density on coefficients induces a different density on each component  $\mathbb{R}^L \times \mathbb{C}^M$ —that is the joint density on roots is naturally described as a set of conditional densities based on the number of real roots.

The map  $E_{L,M} : \mathbb{R}^L \times \mathbb{C}^M \rightarrow \mathbb{R}^N$  specified by  $(\boldsymbol{\alpha}, \boldsymbol{\beta}) \mapsto \mathbf{b}$  where

$$\prod_{l=1}^L (x - \alpha_l) \prod_{m=1}^M (x - \beta_m)(x - \bar{\beta}_m) = x^N + \sum_{n=1}^N b_n x^{N-n}$$

is the map from roots to coefficients, and a generic  $\mathbf{b} \in \mathbb{R}^N$  has  $2^M M!L!$  preimages under this map. The conditional joint density of roots is determined from the Jacobian of  $E_{L,M}$ , which was computed in [35]. Specifically, the conditional joint density of roots of random polynomials with exactly  $L$  real roots is given by  $P_{L,M} : \mathbb{R}^L \times \mathbb{C}^M \rightarrow [0, \infty)$  where

$$P_{L,M}(\boldsymbol{\alpha}, \boldsymbol{\beta}) = \frac{2^M}{Z_{L,M}} \prod_{l=1}^L \max\{1, |\alpha_l|\}^{-s} \prod_{m=1}^M \max\{1, |\beta_m|\}^{-2s} |\Delta(\boldsymbol{\alpha}, \boldsymbol{\beta})|, \quad (1.4)$$

and  $\Delta(\boldsymbol{\alpha}, \boldsymbol{\beta})$  is the Vandermonde determinant in the variables  $\alpha_1, \dots, \alpha_L, \beta_1, \bar{\beta}_1, \dots, \beta_M, \bar{\beta}_M$ , and  $Z_{L,M}$  is the conditional partition function<sup>5</sup>,

$$Z_{L,M}(s) = 2^M \int_{\mathbb{R}^L} \int_{\mathbb{C}^M} \prod_{l=1}^L \max\{1, |\alpha_l|\}^{-s} \prod_{m=1}^M \max\{1, |\beta_m|\}^{-2s} |\Delta(\boldsymbol{\alpha}, \boldsymbol{\beta})| d\mu_{\mathbb{R}}^L(\boldsymbol{\alpha}) d\mu_{\mathbb{C}}^M(\boldsymbol{\beta})$$

( $\mu_{\mathbb{R}}, \mu_{\mathbb{R}}^L, \mu_{\mathbb{C}}, \mu_{\mathbb{C}}^M$  are Lebesgue measure on  $\mathbb{R}, \mathbb{R}^L, \mathbb{C}$  and  $\mathbb{C}^M$  respectively).

The total partition function is then given by

$$Z(s) = \sum_{\substack{(L,M) \\ L+2M=N}} \frac{Z_{L,M}(s)}{2^M L! M!} = F(s). \quad (1.5)$$

That is, the total partition function of the system is, up to a trivial constant, the volume of  $B_{(N+1)/s}$ .

**Theorem 1.1** (S.-J. Chern, J. Vaaler [6]). *Let  $J$  be the integer part of  $N/2$ , and suppose  $s > N$ . Then,*

$$F(s) = C_N \prod_{j=0}^J \frac{s}{s - (N - 2j)} \quad \text{where} \quad C_N = 2^N \prod_{j=1}^J \left( \frac{2j}{2j+1} \right)^{N-2j}. \quad (1.6)$$

This theorem is surprising, in part because of the simplicity of the representation as a function of  $s$ , but also because by (1.5),  $F(s)$  is initially given as a rather complicated sum whereas (1.6) reveals it as a relatively simple product. It should be remarked that constituent summands,  $Z_{L,M}(s)$ , are *not* simple, and Chern and Vaaler’s remarkable product identity followed from dozens of pages of complicated rational function identities.

A conceptual explanation for Chern and Vaaler’s product formulation of  $F(s)$  is given by the following theorem.

<sup>5</sup> *Partition function* is physics parlance for “normalization constant.”



and  $\beta_1, \dots, \beta_M$  represent the complex roots in the open upper half-plane (here  $L$  and  $M$  are random variables too), then given  $A \subseteq \mathbb{R}$  and  $B \subseteq \mathbb{H}$  we define the random variables  $N_A$  and  $N_B$  by

$$N_A = \#A \cap \{\alpha_1, \dots, \alpha_L\} \quad \text{and} \quad N_B = \#B \cap \{\beta_1, \dots, \beta_M\}.$$

That is,  $N_A$  counts the number of roots in  $A$  and takes values in  $1, 2, \dots, N$ . Similarly,  $N_B$  takes values in  $1, 2, \dots, J = \lfloor N/2 \rfloor$ .

If there exists a function  $R_{\ell, m} : \mathbb{R}^\ell \times \mathbb{H}^m \rightarrow [0, \infty)$  so that

$$E [N_{A_1} \cdots N_{A_\ell} N_{B_1} \cdots N_{B_m}] = \int_{A_1} \cdots \int_{A_\ell} \int_{B_1} \cdots \int_{B_m} R_{\ell, m}(\mathbf{x}, \mathbf{z}) d\mu_{\mathbb{R}}^\ell(\mathbf{x}) d\mu_{\mathbb{C}}^m(\mathbf{z}), \quad (1.9)$$

then we call  $R_{\ell, m}$  the  $(\ell, m)$ -*correlation* (or *intensity*) *function*. See [5] for a discussion of these types of two-species correlation functions, or [17] for a more in-depth discussion of one-species correlation functions.

Of particular note, at least for understanding the importance of correlation functions, is the fact that  $N_{\mathbb{R}} = L$ ,  $N_{\mathbb{H}} = M$ , and

$$E[L] = \int_{\mathbb{R}} R_{1,0}(x, -) d\mu_{\mathbb{R}}(x), \quad E[M] = \int_{\mathbb{H}} R_{0,1}(-, z) d\mu_{\mathbb{C}}(z).$$

If we extend  $R_{0,1}(-, z)$  to all of  $\mathbb{C}$  by demanding  $R_{0,1}(-, \bar{z}) = R_{0,1}(-, z)$  (which we could likewise do for the other correlation functions), we find

$$E[2M] = \int_{\mathbb{C}} R_{0,1}(-, z) d\mu_{\mathbb{C}}(z),$$

and

$$N = \int_{\mathbb{R}} R_{1,0}(x, -) d\mu_{\mathbb{R}}(x) + \int_{\mathbb{C}} R_{0,1}(-, z) d\mu_{\mathbb{C}}(z). \quad (1.10)$$

When the random polynomials have i.i.d. coefficients, The functions  $R_{1,0}$  and  $R_{0,1}$  are exactly those given by Kac [19] and Shepp and Vanderbei [33].

Equation (1.10) implies that  $R_{1,0}/N$  gives the spatial density of real roots of random polynomials, and  $R_{0,1}/N$  gives the spatial density of complex roots.

**Theorem 1.3** (Borodin, Sinclair [4, 5]). *The roots of our random polynomials form a Pfaffian point process. That is, there exist a  $2 \times 2$  matrix kernel  $\mathbf{K}_N : \mathbb{C} \times \mathbb{C} \rightarrow \mathbb{C}^{2 \times 2}$ , such that  $R_{\ell, m}$  exists, and*

$$R_{\ell, m}(\mathbf{x}, \mathbf{z}) = \text{Pf} \begin{bmatrix} [\mathbf{K}_N(x_i, x_j)]_{i,j=1}^\ell & [\mathbf{K}_N(x_i, z_n)]_{i,n=1}^{\ell, m} \\ -[\mathbf{K}_N^\top(z_k, x_j)]_{k,j=1}^{m, \ell} & [\mathbf{K}_N(z_k, z_n)]_{k,n=1}^m \end{bmatrix}. \quad (1.11)$$

This kernel takes different forms depending on whether the arguments are real or not; the exact details of this are described below. The importance of (1.11) is the fact that  $\mathbf{K}_N$  is independent of  $\ell$  and  $m$ ; that is, the same kernel appears in the Pfaffian formulation of all correlation functions. Moreover,  $N$  appears as a parameter in the definition of  $\mathbf{K}_N$  in a way that allows for us to compute its limit as  $N \rightarrow \infty$  in various scaling regimes.

The entries of  $\mathbf{K}_N(u, v)$  are traditionally denoted something like

$$\mathbf{K}_N(u, v) = \begin{bmatrix} S_N D(u, v) & S_N(u, v) \\ -S_N(v, u) & IS_N(u, v) + \frac{1}{2} \operatorname{sgn}(u - v) \end{bmatrix}.$$

This notation stems from the fact that, for  $\beta = 1$  Hermitian ensembles (the eigenvalues of which also form Pfaffian point processes—see [31]), the analogous (1, 1) and (2, 2)-entries are given more-or-less by the *Derivative* (with respect to the second variable) and the (running) *Integral* (with respect to the first variable) of the  $S_N$  term. For the kernels we consider here—those appearing in (1.11)—there is still a relationship between the various entries of  $\mathbf{K}_N$ , though this relationship is dependent on whether the arguments are real or complex. We will thoroughly explain this relationship in the sequel, but for now we remark only that when both arguments are real the derivative/running integral relationship between  $S_N D$ ,  $IS_N$  and  $S_N$  persists. Once the relationship between the entries of  $\mathbf{K}_N$  is explained, it suffices to report on only one entry, and for us it will be more convenient to describe one of  $S_N D$  and  $IS_N$  instead of  $S_N$ . Thus, we will use the notation for  $\mathbf{K}_N$  given as in the following theorem.

**Theorem 1.4** (Borodin, Sinclair [4, 5]). *Suppose  $N$  is even. With  $p_0, p_1, \dots, p_{N-1}$  and  $\mathbf{U}$  as in Theorem 1.2, write  $\mu_{m,n}$  for the  $(m, n)$ -entry of  $\mathbf{U}^{-1}$ , and define*

$$\varkappa_N(u, v) = -2 \max\{1, |u|\}^{-s} \max\{1, |v|\}^{-s} \sum_{n,m=1}^N \mu_{m,n} p_{m-1}(u) p_{n-1}(v).$$

Then,

$$\mathbf{K}_N(u, v) = \begin{bmatrix} \varkappa_N(u, v) & \varkappa_N \epsilon(u, v) \\ \epsilon \varkappa_N(u, v) & \epsilon \varkappa_N \epsilon(u, v) + \frac{1}{2} \operatorname{sgn}(u - v) \end{bmatrix}, \quad (1.12)$$

where  $\operatorname{sgn}(u - v)$  is taken to be 0 if either  $u$  or  $v$  is non-real and  $\epsilon$  is the operator

$$\epsilon f(u) := \begin{cases} \frac{1}{2} \int_{\mathbb{R}} f(t) \operatorname{sgn}(t - u) d\mu_{\mathbb{R}}(t) & \text{if } u \in \mathbb{R}, \\ i \operatorname{sgn}(\operatorname{Im}(u)) f(\bar{u}) & \text{if } u \in \mathbb{C} \setminus \mathbb{R}, \end{cases} \quad (1.13)$$

which acts on  $\varkappa_N(u, v)$  as a function of  $u$ , when written on the left and acts on  $\varkappa_N(u, v)$  as a function of  $v$  when written on the right.

Notice that if  $x \in \mathbb{R}$  and  $F$  is an antiderivative of  $f$ , then

$$\epsilon f(x) = -\frac{1}{2} \int_{-\infty}^x f(t) d\mu_{\mathbb{R}}(t) + \frac{1}{2} \int_x^{\infty} f(t) d\mu_{\mathbb{R}}(t) = -F(x) + \frac{F(\infty) + F(-\infty)}{2}.$$

It follows then that, if  $D$  stands for differentiation, then  $D\epsilon f(x) = -f(x)$ . Hence, we can write the entries of  $\mathbf{K}_N$  in terms of  $\epsilon \varkappa_N \epsilon(x, y)$ ,  $x, y \in \mathbb{R}$ , differentiation and complex conjugation.

### 1.5 Scaling Limits

Our primary interest is in the scaling limits of the various matrix kernels as  $N \rightarrow \infty$ .

The scaled kernels hold information about the limiting distribution of roots in a neighborhood of a point on a scale where the expected number of roots in a neighborhood is of order 1. In order to describe the relevant kernels we will use the heuristic assumption that, with probability tending to 1, the roots of random polynomials of large degree are nearly uniformly distributed on the unit circle. We will not prove this assumption since it motivates the discussion here, but is not logically necessary for the present discussion.

Under this assumption, if  $\zeta$  is a point on the unit circle, then when  $N$  is large we expect to see  $O(1)$  roots of a random polynomial in a ball about  $\zeta$  of radius  $1/N$ . Supposing momentarily that  $\zeta$  is a non-real point on the unit circle, and  $\varepsilon > 0$  is sufficiently small so that the ball of radius  $\varepsilon$  about  $\zeta$  does not intersect the real line, then the expected number of roots in this ball is given by

$$\int_{\zeta + \varepsilon \mathbb{D}} \text{Pf}(\mathbf{K}_N(z, z)) \, d\mu_{\mathbb{C}}(z),$$

where  $\mathbb{D} \subset \mathbb{C}$  is the unit disk. After a change of variables this becomes

$$\int_{\mathbb{D}} \varepsilon^2 \text{Pf}(\mathbf{K}_N(\zeta + \varepsilon z, \zeta + \varepsilon z)) \, d\mu_{\mathbb{C}}(z). \tag{1.14}$$

When  $\varepsilon = 1/N$ , using properties of Pfaffians (akin to the multilinearity of the determinant), we have

$$\int_{\mathbb{D}} \text{Pf} \left( \frac{1}{N^2} \mathbf{K}_N \left( \zeta + \frac{z}{N}, \zeta + \frac{z}{N} \right) \right) \, d\mu_{\mathbb{C}}(z). \tag{1.15}$$

We expect that this quantity will converge as  $N \rightarrow \infty$ , and for  $\zeta$  a non-real point on the unit circle, we define

$$\mathbf{K}_{\zeta}(z, w) := \lim_{N \rightarrow \infty} \frac{1}{N^2} \mathbf{K}_N \left( \zeta + \frac{z}{N}, \zeta + \frac{w}{N} \right). \tag{1.16}$$

We will see that this scaled limit is essentially independent of  $\zeta$  (more specifically it depends only trivially on the argument of  $\zeta$ ).

The real points on the unit circle,  $\xi = \pm 1$  are not generic, since for any neighborhood, and all finite  $N$ , there will be a positive (expected) proportion of real roots. This fact is reflected in the emergence of a new limiting kernel in scaled neighborhoods of  $\pm 1$ . In this case, suppose  $A_1, A_2, \dots, A_{\ell}$  and  $B_1, B_2, \dots, B_m$  are measurable subsets of  $\mathbb{R}$  and  $\mathbb{C} \setminus \mathbb{R}$  with positive measure,  $\xi = \pm 1$ , and define the shifted and dilated sets

$$\tilde{A}_j := \xi + \frac{1}{N} A_j \quad \text{and} \quad \tilde{B}_k = \xi + \frac{1}{N} B_k,$$

for  $j = 1, \dots, \ell$  and  $k = 1, \dots, m$ . By our previous reasoning, and the fact that the point process on the roots has Pfaffian correlations (equations (1.9) and (1.11)) we have

$$\begin{aligned} E \left[ N_{\tilde{A}_1} \cdots N_{\tilde{A}_{\ell}} N_{\tilde{B}_1} \cdots N_{\tilde{B}_m} \right] &= \int_{A_1} \cdots \int_{A_{\ell}} \int_{B_1} \cdots \int_{B_m} N^{-\ell-2m} \\ &\times \text{Pf} \begin{bmatrix} [\mathbf{K}_N(\xi + \frac{x_i}{N}, \xi + \frac{x_j}{N})]_{i,j=1}^{\ell} & [\mathbf{K}_N(\xi + \frac{x_i}{N}, \xi + \frac{z_n}{N})]_{i,n=1}^{\ell,m} \\ -[\mathbf{K}_N^{\top}(\xi + \frac{z_k}{N}, \xi + \frac{x_j}{N})]_{k,j=1}^{m,\ell} & [\mathbf{K}_N(\xi + \frac{z_k}{N}, \xi + \frac{z_n}{N})]_{k,n=1}^m \end{bmatrix} d\mu_{\mathbb{R}}^{\ell}(\mathbf{x}) d\mu_{\mathbb{C}}^m(\mathbf{z}). \end{aligned} \tag{1.17}$$



Besides the explicit identification of  $\mathbf{K}_\xi$  and  $\mathbf{K}_\zeta$  we will also produce unscaled limits of  $\mathbf{K}_N(u, v)$  when  $u$  and  $v$  are away from the unit circle. For  $u, v$  in the open unit disk we will find that this unscaled limit exists, and is non-zero; a fact that implies (among other things) that the number of roots in an open subset of the open unit disk has positive expectation, and this expectation converges to a finite number as  $N \rightarrow \infty$ . When  $u$  and  $v$  are outside the closed disk, the convergence of the unscaled limit depends on the asymptotic behavior of  $N/s$ , and we will give an account of the situation there<sup>7</sup>. These results reflect the fact that although ‘most’ of the roots accumulate nearby the unit circle as  $N \rightarrow \infty$  one expects that there will always be a finite number of outliers away from the unit circle.

## 1.6 Notation

In order to expedite the presentation of the various kernels and their scaling limits we introduce some simplifying notation. Firstly we will use  $\mathbb{T}$  for the unit circle in the complex plane,  $\mathbb{D}$  to be the open unit disk, and  $\mathbb{O} := \mathbb{C} \setminus \overline{\mathbb{D}}$ . We will continue to use  $\zeta$  for a non-real point on  $\mathbb{T}$ ,  $\xi$  for  $\pm 1$ . We will also use  $u, v$  for generic complex variables,  $x, y$  for real variables and  $w, z$  for non-real complex variables, so that for instance  $\mathbf{K}_\xi(x, y)$  will mean the scaling limit of the kernel in a neighborhood of  $\pm 1$  corresponding to correlations between real roots. Note that  $\mathbf{K}_\xi(z, x) = -\mathbf{K}_\xi(x, z)^\top$  so we need only report one of these kernels.

Notice that the kernels  $\mathbf{K}_N$  depend on the parameter  $s$ . In what follows we always assume that  $s = s(N) > N$ . Since  $s$  must scale with  $N$  in some manner, we shall always assume that

$$\lambda := \lim_{N \rightarrow \infty} Ns^{-1} \in [0, 1]$$

exists. In our previous discussion, as the parameter for homogeneity in the  $M_\lambda$ ,  $\lambda$  was *exactly* equal to  $(N + 1)s^{-1}$  (or rather,  $s$  was defined to be  $(N + 1)/\lambda$ ), however for the following results we only need that  $s(N) > N$  and an asymptotic description for  $\lambda$ . This generalization will also be useful in Section 3, where we introduce other models with the same statistics as the roots of our random polynomials, and in which the parameters  $s$  and  $\lambda$  have a different meaning. We include the possibility  $s = \infty$ , in which case we take  $\lambda = 0$  and we interpret  $\max\{1, |z|\}^{-\infty}$  as the characteristic function of the closed unit disk.

We remark that, since  $\mathbf{K}_N$  is implicitly dependent on  $s$ , and similarly  $\mathbf{K}_\zeta$  and  $K_\xi$  are dependent on  $\lambda$ . To simplify notation we will often leave any dependence on  $s$  and  $\lambda$  implicit.

## 1.7 The Mahler Ensemble of Complex Polynomials

Before proceeding to our results we will review the complex version of the Mahler ensemble since it both provides context and sets us up to demonstrate a non-trivial connection between these two ensembles.

The complex Mahler ensemble of random polynomials is that formed by choosing degree  $N$  polynomials with *complex* coefficients uniformly (with respect to Lebesgue measure on coefficient vectors) from the set of polynomials with Mahler measure at most 1. The complex Mahler ensemble has many features in common with its real counterpart, for instance we still expect the empirical measure for the roots of a random complex polynomial to weakly converge to uniform measure on the unit circle (in fact, in this case a large deviation result—due to the second author—quantifying this convergence is known [39]). There are striking

<sup>7</sup>The dependence on the limit of  $N/s$  is to be expected, since the larger  $s$  is relative to  $N$ , the smaller the joint density of roots outside the closed unit disk.

differences as well, most conspicuously the roots are generically complex and the spatial density of roots is radial for finite  $N$ .

The joint density of roots is easily computed in this situation (in fact, it is much easier to compute than the conditional joint densities for the real ensemble) and is proportional to

$$\prod_{n=1}^N \max\{1, |z_n|\}^{-2s} \prod_{m < n} \log |z_n - z_m|^2.$$

From the joint density of roots, it is straightforward to show that the spatial process on roots forms a determinantal point process on  $\mathbb{C}$ . That is, there exists a function  $K_N : \mathbb{C} \times \mathbb{C} \rightarrow \mathbb{C}$  such that if  $B_1, \dots, B_n$  are disjoint subsets of  $\mathbb{C}$ , then

$$E[N_{B_1} \cdots N_{B_n}] = \int_{B_1} \cdots \int_{B_n} \det [K_N(z_j, z_k)]_{j,k=1}^n d\mu_{\mathbb{C}}^n(\mathbf{z}).$$

In other words, the  $n$ th correlation function can be expressed as the determinant of an  $n \times n$  matrix, the entries of which are formed from the scalar kernel  $K_N$ .

Our previous arguments suggest the relevant scaling limit is

$$K_{\zeta}(z, w) := \lim_{N \rightarrow \infty} \frac{1}{N^2} K_N \left( \zeta + \frac{z}{N}, \zeta + \frac{w}{N} \right).$$

We recount the scaling limit of the kernel here, since we will find a relationship between it and the scaling limit for the matrix kernel(s) for the real Mahler ensemble.

**Theorem 1.5** (Sinclair, Yattselev [37]). *Let  $\lambda = \lim_{N \rightarrow \infty} Ns^{-1}$ . Then  $K_{\zeta}(z, w)$ ,  $\zeta \in \mathbb{T}$ , exists and*<sup>8</sup>

$$K_{\zeta}(z, w) = \omega(z\bar{\zeta})\omega(\bar{w}\zeta) \frac{1}{\pi} \int_0^1 x(1-\lambda x) e^{(z\bar{\zeta} + \bar{w}\zeta)x} dx, \quad (1.21)$$

where

$$\omega(\tau) := \min \left\{ 1, e^{-\operatorname{Re}(\tau)/\lambda} \right\} = \lim_{N \rightarrow \infty} \max \left\{ 1, \left| 1 + \frac{\tau}{N} \right| \right\}^{-s}. \quad (1.22)$$

Moreover, it holds that

$$\lim_{N \rightarrow \infty} K_N(z, w) = \frac{1}{\pi} \frac{1}{(1 - z\bar{w})^2}$$

locally uniformly in  $\mathbb{D} \times \mathbb{D}$ , and, if  $s < \infty$  for each finite  $N$ ,

$$\lim_{N \rightarrow \infty} \frac{|z\bar{w}|^s}{(z\bar{w})^N} \frac{K_N(z, w)}{s - N} = \frac{1}{\pi} \frac{1}{z\bar{w} - 1} \left[ 1 + \frac{c^{-1}}{z\bar{w} - 1} \right]$$

locally uniformly in  $\mathbb{O} \times \mathbb{O}$ , where  $c := \lim_{N \rightarrow \infty} (s - N)$ .

The main result of [37] was the universality of the kernel  $K_{\zeta}$  under conformal maps which map the exterior of the unit disk onto the exterior of compact sets with smooth boundary. The details of this universality are unimportant here; instead we recount Theorem 1.5 since the entries for the kernel(s) for the real Mahler ensemble depend also on  $K_{\zeta}$ .

<sup>8</sup>In [37], the integral in formula (1.21) is evaluated explicitly. The form given there can be easily obtained from [37, Eq. (23) & (71)] and elementary integration. The form given here is more readily generalized, a fact which becomes useful later.



## 2 Main Results

### 2.1 The Expected Number of Real Roots

**Theorem 2.1.** *Let  $N_{\text{in}}$  and  $N_{\text{out}}$  be the number of real roots on  $[-1, 1]$  and  $\mathbb{R} \setminus (-1, 1)$ , respectively, of a random degree  $N$  polynomial chosen from the real Mahler ensemble. Then*

$$\begin{cases} E[N_{\text{in}}] &= \frac{1}{\pi} \log N + O_N(1) \\ E[N_{\text{out}}] &= -\frac{1}{\pi} \frac{\sqrt{N(2s-N)}}{s} \log(1 - Ns^{-1}) + \sqrt{Ns^{-1}} O_N(1), \end{cases}$$

where the implicit constants are uniform with respect to  $s$ .

Observe that

$$E[N_{\text{out}}] = \begin{cases} \sqrt{Ns^{-1}} O_N(1), & \limsup_{N \rightarrow \infty} Ns^{-1} < 1, \\ \frac{\alpha}{\pi} \log N + O_N(1), & s = N + N^{1-\alpha}, \alpha \in [0, 1], \\ \frac{1}{\pi} \log N + O_N(1), & \limsup_{N \rightarrow \infty} (s - N) < \infty. \end{cases}$$

In particular, in the third case, the leading term of the expected number of real roots of a random polynomial from the real Mahler ensemble is  $\frac{2}{\pi} \log N$ , which matches exactly the leading term of the expected number of real roots of a random polynomial with independent standard normal coefficients obtained by Kac [19].

### 2.2 Kernel Limits Near the Unit Circle

Our first result states that the limiting local correlations at  $\zeta \in \mathbb{T} \setminus \{-1, 1\}$  can be given in terms of the scaled scalar kernel for the complex Mahler ensemble.

**Theorem 2.2.** *Let  $\zeta \in \mathbb{T} \setminus \{\pm 1\}$  and  $\mathbf{K}_\zeta$  be the scaling limit of the matrix kernel (1.12) defined by (1.16). Then*

$$\mathbf{K}_\zeta(z, w) = \begin{bmatrix} 0 & K_\zeta(z, w) \\ -K_\zeta(w, z) & 0 \end{bmatrix}$$

with the limit in (1.16) holding locally uniformly for  $z, w \in \mathbb{C}$ , where  $K_\zeta(z, w)$  is the scaling limit of the scalar kernel for the complex Mahler ensemble given by (1.21).

Observe that

$$\text{Pf} \begin{bmatrix} 0 & K_\zeta(z_j, z_k) \\ -K_\zeta(z_k, z_j) & 0 \end{bmatrix}_{j,k=1}^n = \det [K_\zeta(z_j, z_k)]_{j,k=1}^n,$$

and thus we have that the limiting local distribution of roots of real random polynomials at a point in  $\mathbb{T} \setminus \{-1, 1\}$  collapses to a determinantal point process identical to that for the complex Mahler ensemble at the same point.

A new kernel arises in a neighborhood of  $\xi = \pm 1$ . As in (1.22),  $\omega(\tau) = \min\{1, e^{-\text{Re}(\tau)/\lambda}\}$ , interpreting this as the characteristic function on the closed unit disk in the case  $\lambda = 0$ . We also define

$$M(z) := \frac{1}{\Gamma(3/2)} \sum_{n=0}^{\infty} \frac{\Gamma(n+3/2)}{\Gamma(n+1)} \frac{z^n}{n!} = {}_1F_1(3/2, 1; z).$$

We remark that  $M(z)$  can be expressed rather succinctly in terms of modified Bessel functions, though we have no reason to do that here.

**Theorem 2.3.** For  $\xi = \pm 1$ , let  $\varkappa_\xi(u, v)$  be defined by (1.19) & (1.20). Then

$$\varkappa_\xi(u, v) = \omega(u\xi)\omega(v\xi)\frac{\xi}{4}\int_0^1 \tau(1-\lambda\tau)[M'(u\xi\tau)M(v\xi\tau) - M(u\xi\tau)M'(v\xi\tau)]d\tau, \quad (2.1)$$

where  $\omega(\tau)$  is defined by (1.22) and the convergence in (1.19) is uniform on compact subsets of  $\mathbb{C} \times \mathbb{C}$ .

For the sake of brevity, we shall use the following notation:

$$\iota(z) := i \operatorname{sgn}(\operatorname{Im}(z)). \quad (2.2)$$

Because  $\epsilon$  operator (1.13) amounts to conjugation and multiplication by  $\iota$  for complex arguments and since  $\bar{\xi} + \frac{u}{N} = \xi + \frac{\bar{u}}{N}$ , it is clear that (1.20) is indeed the limit of (1.19) when  $u, v \in \mathbb{C} \setminus \mathbb{R}$  and the following corollary takes place.

**Corollary 2.4.** If  $z, w \in \mathbb{C} \setminus \mathbb{R}$ , then

$$\mathbf{K}_\xi(z, w) = \begin{bmatrix} \varkappa_\xi(z, w) & \iota(w)\varkappa_\xi(z, \bar{w}) \\ -\iota(z)\varkappa_\xi(w, \bar{z}) & \iota(z)\iota(w)\varkappa_\xi(\bar{z}, \bar{w}) \end{bmatrix}. \quad (2.3)$$

As already been suggested in (1.20) following the discussion after Theorem 1.4, the remaining kernels are most conveniently reported in terms of the (2, 2) entry of  $\mathbf{K}_\xi(x, y)$ , and thus we introduce the following notation.

$$\left\{ \begin{array}{l} \mathbf{K}[A](x, y) = \begin{bmatrix} DAD(x, y) & -DA(x, y) \\ AD(x, y) & A(x, y) + \frac{1}{2} \operatorname{sgn}(y - x) \end{bmatrix}, \\ \mathbf{K}[A](z, y) = \begin{bmatrix} DAD(z, y) & -DA(z, y) \\ \iota(z)DAD(\bar{z}, y) & -\iota(z)DA(\bar{z}, y) \end{bmatrix}, \\ \mathbf{K}[A](y, z) = -\mathbf{K}[A]^\top(z, y), \\ \mathbf{K}[A](z, w) = \begin{bmatrix} DAD(z, w) & \iota(w)DAD(z, \bar{w}) \\ \iota(z)DAD(\bar{z}, w) & \iota(z)\iota(w)DAD(\bar{z}, \bar{w}) \end{bmatrix}, \end{array} \right. \quad (2.4)$$

where  $D$  is differentiation with respect to the first (second) variable when written on the left (right).

**Theorem 2.5.** For  $\xi = \pm 1$ , define

$$A_\xi(a, b) := \int_0^a \int_0^b \varkappa_\xi(u, v) du dv + \left( \int_0^b - \int_0^a \right) \left[ \frac{\omega(v\xi)}{4} \int_0^1 (1 - \lambda u) M(v\xi u) du \right] dv. \quad (2.5)$$

Then  $\mathbf{K}_\xi(u, v) = \mathbf{K}[A_\xi](u, v)$  where the convergence in (1.19) is locally uniform on  $\mathbb{C} \times \mathbb{C}$ .

Expression (2.5) can be simplified when  $u\xi, v\xi < 0$  as in this case  $\omega(u\xi) = \omega(v\xi) = 1$ . Recall that  $M$  is a confluent hypergeometric function and therefore is a solution of the

second order differential equation, namely,  $zM''(z) + (1 - z)M'(z) - \frac{3}{2}M(z) = 0$ . Then, if we define  $I(z) := 2z(M' - M)(z)$  (and therefore  $I'(z) = M(z)$ ), we can write

$$A_\xi(a, b) = \frac{\xi}{4} \int_0^1 \frac{1 - \lambda\tau}{\tau} \left( I'(a\xi\tau)I(b\xi\tau) - I(a\xi\tau)I'(b\xi\tau) \right) d\tau,$$

which bears a striking structural resemblance to  $\varkappa_\xi$ .

Let us compare one consequence of Theorem 2.3 (via Corollary 2.4) with the analogous situation for complex random polynomials. This theorem implies that we can compute the large  $N$  limit of the expected number of roots in a set of the form  $\xi + \frac{1}{N}B$ , disjoint from the real axis, by integrating

$$\text{Pf } \mathbf{K}_\xi(z, z) = \iota(z)\varkappa_\xi(z, \bar{z})$$

over  $B$ . (This function is the scaled *intensity* of complex roots near  $\xi$ ).

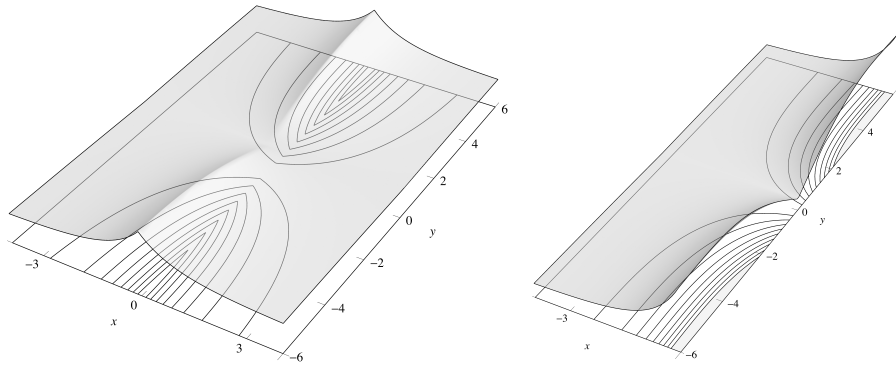

Figure 2: The scaled intensity of complex roots near 1, for  $\lambda = 1$  (left) and  $\lambda = 0$  (right). Note how the roots tend to accumulate near the unit disk (the  $y$ -axis here) and repel from the real axis.

This formula is not valid when  $z = \bar{z}$ , since in that case, the Pfaffian of  $\mathbf{K}[A_\xi](x, x)$  is responsible for the expected number of (real) roots. However, as  $z \rightarrow \bar{z}$  ( $= w$ ), we see that the integrand in (2.1), and hence the intensity of complex roots goes to zero. This is not surprising, since the conditional joint densities of roots, (1.4), vanishes there. Loosely speaking, roots repel each other, including those that are complex conjugates of each other, and this causes an expected scarcity of complex roots near the real axis. The fact that this phenomenon is visible on the scale  $1/N$  is worth noting if not particularly surprising.

Since the complex ensemble has no conjugate symmetry, we should not expect the corresponding integrand to vanish. In this case, according to Theorem 1.5 the local intensity of roots near  $\xi$  is governed by

$$\omega(z\xi)\omega(\bar{z}\xi) \frac{1}{\pi} \int_0^1 \tau(1 - \lambda\tau)e^{2\text{Re}(z)\xi\tau} d\tau,$$

which is remarkably similar to  $\iota(w)\varkappa_\xi(z, \bar{z})$  aside from the obvious considerations due to root symmetry.

One expects that, as  $|\operatorname{Im}(z)| \rightarrow \infty$  the local intensity of complex roots in the real ensemble will approach the local intensity of roots in the complex ensemble, since in this limit the repulsion from complex conjugates vanishes. This is indeed the case.

**Lemma 2.6.** *It holds that*

$$\lim_{|\operatorname{Im}(z)| \rightarrow \infty} \frac{\iota(z)}{4} \left[ M'(z)M(\bar{z}) - M(z)M'(\bar{z}) \right] = \frac{e^{2\operatorname{Re}(z)}}{\pi}$$

### 2.3 Kernel Limits Away from the Unit Circle

In this section we discuss the asymptotics of the matrix kernels  $\mathbf{K}_N$  away from the unit circle. In this case, the scale of the neighborhood about a point  $\omega \in \mathbb{C} \setminus \mathbb{T}$  will not depend on  $N$ . As we show below, the kernels  $\mathbf{K}_N$  converge uniformly in a neighborhood of any such point, and hence it suffices to investigate the asymptotics of  $\mathbf{K}_N(u, v)$ . It will turn out that the asymptotics are different depending on whether or not  $z, w$  are inside or outside the disk.

We start by considering the case of the unit disk.

**Theorem 2.7.** *For  $u, v \in \mathbb{D}$ , set*

$$A_{\mathbb{D}}(u, v) := \frac{1}{4\pi} \int_{\mathbb{T}} \frac{(v\sqrt{-\tau} - u\sqrt{-\bar{\tau}}) |d\tau|}{(1 - u^2\bar{\tau})^{1/2} (1 - v^2\tau)^{1/2}}, \quad (2.6)$$

where  $\sqrt{-\tau}$  is the branch defined by  $-\frac{2}{\pi} \sum_{-\infty}^{\infty} \frac{\tau^m}{2m-1}$ ,  $\tau \in \mathbb{T}$ . Then  $\lim_{N \rightarrow \infty} \mathbf{K}_N(u, v) = \mathbf{K}[A_{\mathbb{D}}](u, v)$  locally uniformly on  $\mathbb{D} \times \mathbb{D}$ .

Among the implications of this theorem is that the unscaled intensity of roots converges on compact subsets of  $\mathbb{D}$ . In particular, this implies that if  $B \subset \mathbb{D}$  has non-empty interior, then the expected number of roots in  $B$  converges to a positive quantity (obviously dependent on  $B$ ). In particular, for any  $\varepsilon > 0$  the expected number of roots in the disk  $\{z : |z| < 1 - \varepsilon\}$  converges to a positive number. In words, even though we expect the roots to accumulate uniformly on the unit circle, we also should expect to find a positive number of roots away from  $\mathbb{T}$ .

In order to investigate the situation when  $z, w$  are outside the closed unit disk, we first record the following theorem. In what follows we always assume that  $s < \infty$  for each finite  $N$  as otherwise  $\mathbf{K}_N$  is identically zero in  $\mathbb{O} \times \mathbb{O}$ .

**Theorem 2.8.** *Set  $c := \lim_{N \rightarrow \infty} (s - N) \in [1, \infty]$  and let  $\varkappa_N(u, v)$  be the (1,1)-entry of  $\mathbf{K}_N$  as in (1.12). Then, for  $u, v \in \mathbb{O}$ ,*

$$\lim_{N \rightarrow \infty} \frac{|uv|^s}{(uv)^N} \frac{\varkappa_N(u, v)}{s - N} = \frac{\lambda}{\pi} \left[ 1 + \frac{c^{-1}}{uv - 1} \right] \frac{1}{uv - 1} \frac{v - u}{\sqrt{u^2 - 1}\sqrt{v^2 - 1}} \quad (2.7)$$

locally uniformly in  $\mathbb{O} \times \mathbb{O}$ , where  $c^{-1} = 0$  when  $c = \infty$ .

Note the factor of  $|uv|^s/(uv)^N$ . When  $\lambda < 1$ , this factor diverges at least geometrically fast which yields that

$$\lim_{N \rightarrow \infty} \varkappa_N(u, v) = 0 \quad (2.8)$$

locally uniformly in  $\mathbb{O} \times \mathbb{O}$ . Furthermore, if  $\lambda = 1$  but  $s - N \rightarrow \infty$ , then  $|uv|^{s-N}/(s-N)$  diverges and the conclusion (2.8) holds again. Only in the case where  $c < \infty$ , do we get the non-trivial limit

$$\lim_{N \rightarrow \infty} \frac{|uv|^N}{(uv)^N} \varkappa_N(u, v) = \frac{1}{\pi} \left[ c + \frac{1}{uv - 1} \right] \frac{1}{|uv|^c} \frac{1}{uv - 1} \frac{v - u}{\sqrt{u^2 - 1} \sqrt{v^2 - 1}} =: B(u, v). \quad (2.9)$$

It remains to explain the seemingly superfluous term  $(|uv|/(uv))^N$ . To do this, let  $u_1, u_2, \dots, u_M$  be points outside the unit disk (some could be real, some complex). A general correlation function of  $M$  roots, is given as the Pfaffian of a  $2M \times 2M$  matrix of the form

$$\mathbf{A} = \left[ \mathbf{K}_N(u_i, u_k) \right]_{i,k=1}^M,$$

where the exact structure of  $\mathbf{K}_N(u_i, u_k)$  will depend on whether  $u_i$  and/or  $u_k$  are real or not. (This is essentially the content of (1.11)). It readily follows from (1.12) & (1.13) that for  $u, v \in \mathbb{C} \setminus \mathbb{R}$  each entry of  $\mathbf{K}_N$  possesses a limit identical up to conjugation to (2.7). Thus, we define the block diagonal matrix

$$\mathbf{D} := \begin{bmatrix} \delta_{i,k} (|u_i| / u_i)^N & 0 \\ 0 & \delta_{i,k} (|u_i| / \bar{u}_i)^N \end{bmatrix}_{i,k=1}^M.$$

As  $\mathbf{D}$  is diagonal, we have that  $\text{Pf}(\mathbf{DAD}^*) = \det \mathbf{D} \cdot \text{Pf} \mathbf{A} = \text{Pf} \mathbf{A}$ , and that

$$\mathbf{DAD}^* = \begin{bmatrix} \left( \frac{|u_i| |u_k|}{u_i u_k} \right)^N \varkappa_N(u_i, u_k) & \left( \frac{|u_i| |u_k|}{u_i \bar{u}_k} \right)^N \varkappa_N \epsilon(u_i, u_k) \\ \left( \frac{|u_i| |u_k|}{\bar{u}_i u_k} \right)^N \epsilon \varkappa_N(u_i, u_k) & \left( \frac{|u_i| |u_k|}{\bar{u}_i \bar{u}_k} \right)^N \left\{ \epsilon \varkappa_N \epsilon(u_i, u_k) + \frac{1}{2} \text{sgn}(u_i - u_k) \right\} \end{bmatrix}_{i,k=1}^m.$$

Since our primary interest is in  $\text{Pf}(\mathbf{A})$  and not  $\mathbf{A}$  itself and in light of Theorem 2.8 we shall study

$$\widehat{\mathbf{K}}_N(u, v) := \begin{bmatrix} \left( \frac{|uv|}{uv} \right)^N \varkappa_N(u, v) & \left( \frac{|uv|}{u\bar{v}} \right)^N \varkappa_N \epsilon(u, v) \\ \left( \frac{|uv|}{\bar{u}v} \right)^N \epsilon \varkappa_N^{(2,1)}(u, v) & \left( \frac{|uv|}{\bar{u}\bar{v}} \right)^N \left\{ \epsilon \varkappa_N \epsilon(u, v) + \frac{1}{2} \text{sgn}(u - v) \right\} \end{bmatrix} \quad (2.10)$$

rather than  $\mathbf{K}_N$ .

**Theorem 2.9.** *Let  $c = \lim_{N \rightarrow \infty} (s - N) \in [1, \infty]$ . Set  $A_{\mathbb{O}} \equiv 0$  when  $c = \infty$ , and otherwise define*

$$\begin{aligned} A_{\mathbb{O}}(x, y) := & \int_{\text{sgn}(x)\infty}^x \int_{\text{sgn}(y)\infty}^y B(u, v) du dv \\ & + \frac{1}{\sqrt{\pi}} \frac{\Gamma\left(\frac{c+1}{2}\right)}{\Gamma\left(\frac{c}{2}\right)} \left( \text{sgn}(x) \int_{\text{sgn}(y)\infty}^y - \text{sgn}(y) \int_{\text{sgn}(x)\infty}^x \right) \frac{du}{|u|^c \sqrt{u^2 - 1}}, \end{aligned} \quad (2.11)$$

where  $B(u, v)$  is defined in (2.9). Then  $\lim_{N \rightarrow \infty} \widehat{\mathbf{K}}_N(u, v) = \mathbf{K}[A_{\mathbb{O}}](u, v)$  locally uniformly in  $\mathbb{O} \times \mathbb{O}$ .

*Remark.* The root  $\sqrt{u^2 - 1}$  occurring within the integrals in (2.11) should be understood as the trace on  $\mathbb{R} \setminus (-1, 1)$  of  $\sqrt{z^2 - 1}$  that is holomorphic in  $\mathbb{C} \setminus [-1, 1]$ . In particular, it is negative for negative  $x$ .

*Remark.* Even though the function  $A_{\mathbb{O}}$  is defined for real arguments only, it is a simple algebraic computation to see that  $DA_{\mathbb{O}}$  is well defined when the first argument is complex and  $DA_{\mathbb{O}}D$  is nothing else but  $B(u, v)$  in (2.9).

The intensity of complex roots outside the unit circle is given by  $\iota(z)B(z, \bar{z})$ . Integrating this over a set  $B \subset \mathbb{O}$  yields the expected number of complex roots of random degree  $N$  polynomial in  $B$ . When  $\lambda < 1$  (or more generally when  $c = \infty$ ), we see from (2.8) that the limiting expectation goes to 0. In particular, in this situation, the expected number of roots outside the unit disk goes to 0 with  $N$ . When  $c$  is finite and  $B$  is bounded away from  $\mathbb{T}$  with positive Lebesgue measure, then the expected number of roots in  $B$  will converge to a positive number dependent on  $B$  and  $c$ .

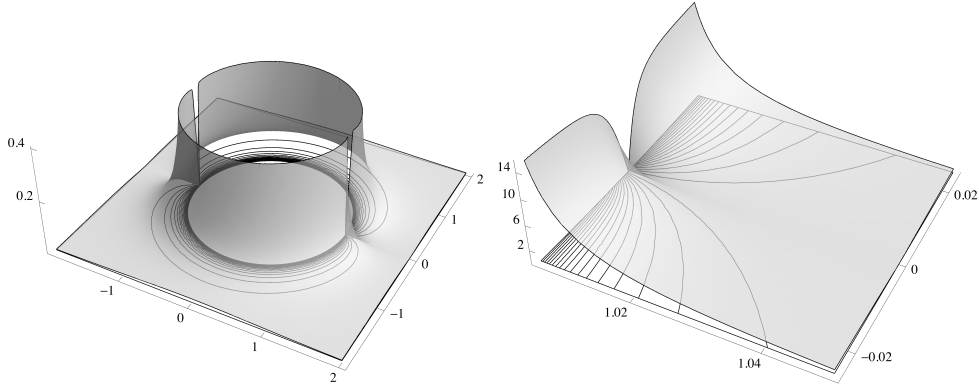

Figure 3: The limiting intensity of complex roots outside the disk, with a close up view near  $z = 1$ , for the Mahler measure ( $c = 1$ ) case.

### 3 Other Ensembles with the Same Statistics

Before proving our main results we also present an electrostatic model and a matrix model which produce the same point process.

#### 3.1 An Electrostatic Model

In two dimensional electrostatics, we identify charged particles with points in the complex plane. An electrostatic system with unit charges located at  $z, z'$  has potential energy  $-\log|z - z'|$  and a system with  $N$  unit charges located at the coordinates of  $z \in \mathbb{C}^N$  has potential energy

$$-\sum_{m < n} \log|z_n - z_m|.$$

The states which minimize this energy correspond to those where the particles are infinitely far apart (*i.e.* the particles repel each other) and in order to counteract this repulsion we introduce a confining potential. There are many possibilities for this confining potential,

but in order to arrive at a model with particle statistics identical to those of the roots of our random polynomials, the potential we introduce is that formed from an oppositely charged region, identified with the unit disk, with total charge  $s$  and charge density representing its equilibrium state. More precisely, the equilibrium charge density is given by its equilibrium measure (in the sense of potential theory in the complex plane [32]) and by symmetry this is simply normalized Lebesgue measure on the unit circle. That is, the interaction energy between the charged unit disk at equilibrium (with total charge  $s$ ) and a unit charge particle at  $z \in \mathbb{C}$  is given by

$$s \int_0^1 \log |z - e^{2\pi i \theta}| d\theta = s \log \max \{1, |z|\},$$

where equality is a consequence of Jensen's formula. It follows that the total energy of the system of particles located at the coordinates of  $\mathbf{z}$  in the presence of the equilibrated charged disk is given by

$$E(\mathbf{z}) = s \sum_{n=1}^N \log \max \{1, |z_n|\} - \sum_{m < n} \log |z_n - z_m|.$$

When the system is at temperature specified by the dimensionless inverse temperature parameter  $\beta = (kT)^{-1}$  the probability density of finding the system in state  $\mathbf{z}$  is given by

$$\frac{e^{-\beta E(\mathbf{z})}}{Z} = \frac{1}{Z} \left\{ \prod_{n=1}^N \max \{1, |z_n|\}^{-\beta s} \right\} \prod_{m < n} \log |z_n - z_m|^\beta$$

where  $Z$  is the *partition function* of the system,

$$Z = \int_{\mathbb{C}^N} e^{-\beta E(\mathbf{z})} d\mu_{\mathbb{C}}^N(\mathbf{z}). \quad (3.1)$$

If we specify that  $\beta = 1$ , exactly  $L$  coordinates of  $\mathbf{z}$  are real and the remaining  $2M = N - L$  come in complex conjugate pairs (which we can think of as mirrored particles) then the probability density of states is exactly the conditional density of roots of random polynomials with exactly  $L$  real roots  $P_{L,M}$ , and the partition function is the conditional partition function  $Z_{L,M}$ .

If we specify that the total charge of all particles is  $N$ , but allow the number of real and complex conjugate pairs of particles to vary, then we arrive at a zero-current (i.e., conserved charge) grand canonical ensemble, whose conditional density for the population vector  $(L, M)$  is given by  $X^L P_{L,M}$  where  $X$  is the *fugacity*, a quantity that encodes how easily the system can change population vectors. The partition function, as a function of the fugacity and the charge on the unit disk, is given by

$$Z(X; s) = \sum_{\substack{(L, M) \\ L+2M=N}} \frac{X^L Z_{L,M}(s)}{2^M L! M!},$$

which, when  $X = 1$  is, up to the factor  $2/(N+1)$ , is the volume of the Mahler measure star body, and as a function of  $X$  is the probability generating function for the probability that the electrostatic configuration has exactly  $L$  real particles, or equivalently that a random polynomial has exactly  $L$  real roots.

### 3.2 A Normal Matrix Model

Given a self-map on a metric space, the entropy is a measure of orbit complexity under repeated iteration of this map. Loosely speaking this quantity measures how far neighboring points can get away from each other under iteration by this map. We will not give a definition of this quantity, since the formulation is complicated and not really necessary here; see [38] for a discussion. When the metric space is  $\mathbb{R}^N$  (or  $\mathbb{C}^N$ ) and the self-map is an  $N \times N$  matrix, then a theorem of Yuzvinsky has that the entropy is the logarithm of the Mahler measure of the characteristic polynomial [40]. That is, if  $\mathbf{M}$  is an  $N \times N$  matrix with eigenvalues  $\lambda_1, \lambda_2, \dots, \lambda_N$  in  $\mathbb{C}$ , then the entropy of  $\mathbf{M}$  is given by

$$h(\mathbf{M}) = \sum_{n=1}^N \log \max \{1, |\lambda_n|\}.$$

Despite not giving a definition of entropy, this is a sensible result since it is clear that the ‘big’ eigenvalues are responsible for nearby points moving away from each other under repeated iteration of  $\mathbf{M}$ .

If we wish to use the entropy to form a probability measure on some set of matrices (equipped with some natural reference measure), an obvious choice is to have the Radon-Nikodym derivative with respect to the reference measure be given by  $e^{-sh(\mathbf{M})}$  where  $s$  is some sufficiently large constant necessary so that the resulting measure is actually finite. Under such a probability measure we would be more likely to choose a matrix with small entropy, large entropies being exponentially rare.

A natural choice for the set of matrices is that of normal matrices. That is matrices which commute with their conjugate transpose. (One reason this is a natural choice is that normal matrices are unitarily equivalent to diagonal matrices, and the entries in the diagonal matrix are independent of the random variables parametrizing the unitary group). When restricting to real normal matrices, the eigenvalues come in real and complex conjugate pairs, and the joint density of eigenvalues naturally decomposes into conditional densities dependent on the number of real eigenvalues. These conditional densities are identical to those given for the real Mahler ensemble of polynomials given in equation (1.4). The derivation of the joint density of eigenvalues uses standard random matrix theory techniques, augmented to deal with the two species of eigenvalues, the details of which are given in Appendix A.

We conclude that the eigenvalue statistics for this *entropic* ensemble of random normal matrices is identical to the particle statistics in the electrostatic model and the root statistics of polynomials chosen randomly from Mahler measure star bodies.

## 4 Matrix Kernels and Skew-Orthogonal Polynomials

The matrix kernel  $\mathbf{K}_N$  can be most simply represented via weighted sums of the *skew-orthonormal polynomials* for the skew-symmetric bilinear form

$$\begin{aligned} \langle f|h \rangle &= \langle f|h \rangle_{\mathbb{R}} + \langle f|h \rangle_{\mathbb{C}} \\ &= \int \left( \tilde{f}(u)\epsilon\tilde{h}(u) - \epsilon\tilde{f}(u)\tilde{h}(u) \right) d(\mu_{\mathbb{C}} + \mu_{\mathbb{R}})(u) \end{aligned} \tag{4.1}$$

where  $\langle \cdot | \cdot \rangle_{\mathbb{R}}$  and  $\langle \cdot | \cdot \rangle_{\mathbb{C}}$  are given as in Theorem 1.2, the operator  $\epsilon$  is given by (1.13),  $\tilde{f}(u) := f(u) \max \{1, |u|\}^{-s}$ , and the functions  $f, h$  satisfy the symmetry  $g(\bar{u}) = \overline{g(u)}$ . Namely, let



$\{\pi_n\}$ ,  $\deg \pi_n = n$ , be a sequence of polynomials such that

$$\langle \pi_{2n} | \pi_{2m} \rangle = \langle \pi_{2n+1}, \pi_{2m+1} \rangle = 0 \quad \text{and} \quad \langle \pi_{2n} | \pi_{2m+1} \rangle = -\langle \pi_{2m+1} | \pi_{2n} \rangle = \delta_{m,n}.$$

Note that this sequence is not uniquely determined since we may replace  $\pi_{2n+1}$  with  $\pi_{2n+1} + c\pi_{2n}$  without disturbing the skew-orthogonality.

**Theorem 4.1.** *For each fixed  $s$ , one possible family of skew-orthonormal polynomials corresponding to bilinear form (4.1) is given by<sup>9</sup>*

$$\begin{cases} \pi_{2n}(z) &= \frac{2}{\pi} \sum_{k=0}^n \frac{\Gamma(k+3/2) \Gamma(n-k+1/2)}{\Gamma(k+1) \Gamma(n-k+1)} z^{2k}, \\ \pi_{2n+1}(z) &= -\frac{1}{2\pi} \sum_{k=0}^n \frac{s-(2k+2)}{2s} \frac{\Gamma(k+3/2) \Gamma(n-k-1/2)}{\Gamma(k+1) \Gamma(n-k+1)} z^{2k+1}. \end{cases}$$

These polynomials were originally produced using the skew analog of the Gram-Schmidt procedure from the previously computed *skew*-moments, see [35, Lemma 4.1].

**Lemma 4.2.**  $\langle z^{2n} | z^{2m} \rangle = \langle z^{2n-1} | z^{2m-1} \rangle = 0$  and,

$$\langle z^{2n} | z^{2m+1} \rangle = \left( \frac{s}{s-2m-2} \right) \frac{1}{\left(n + \frac{1}{2}\right) \left(m - n + \frac{1}{2}\right)}. \quad (4.2)$$

Theorem 4.1 follows from Lemma 4.2 and the following theorem.

**Theorem 4.3.** *Suppose  $\{C_m\}$  is a sequence of non-zero real numbers, and  $\alpha, \beta \in \mathbb{R} \setminus \{-1, -2, \dots\}$  and suppose  $\langle \cdot | \cdot \rangle^{\alpha, \beta}$  is a skew-symmetric inner product with  $\langle z^{2n} | z^{2m} \rangle^{\alpha, \beta} = \langle z^{2n+1} | z^{2m+1} \rangle^{\alpha, \beta} = 0$ , and*

$$\langle z^{2n} | z^{2m+1} \rangle^{\alpha, \beta} = C_m \left\{ \prod_{j=1}^n \frac{j-1-\beta}{j+\alpha} \right\} \frac{1}{m-n+1+\beta}. \quad (4.3)$$

Define

$$\pi_{2n}^{\alpha, \beta}(z) = \frac{1}{\Gamma(1+\alpha) \Gamma(1+\beta)} \sum_{\ell=0}^n \frac{\Gamma(\ell+\alpha+1) \Gamma(n-\ell+\beta+1)}{\Gamma(\ell+1) \Gamma(n-\ell+1)} z^{2\ell},$$

and

$$\pi_{2n+1}^{\beta}(z) = \frac{1}{\Gamma(-\beta-1) \Gamma(1+\beta)} \sum_{\ell=0}^n \frac{\Gamma(\ell+\beta+2) \Gamma(n-\ell-\beta-1)}{\Gamma(\ell+1) \Gamma(n-\ell+1)} \frac{z^{2\ell+1}}{C_\ell}.$$

Then,  $\{\pi_0^{\alpha, \beta}, \pi_1^{\beta}, \pi_2^{\alpha, \beta}, \pi_3^{\beta}, \dots\}$  is a family of skew-orthonormal polynomials for the skew-symmetric inner product  $\langle \cdot | \cdot \rangle^{\alpha, \beta}$ .

It follows immediately from (4.2) and (4.3) that  $\pi_{2n} = \pi_{2n}^{1/2, -1/2}$  and  $\pi_{2n+1} = \pi_{2n+1}^{-1/2}$ , where  $C_m = 2s/(s-2m-2)$ . Thus, with a little bit of algebra, we get that

$$\begin{cases} \pi_{2n}(z) &= \pi_{2n}^{1/2, -1/2}(z) \\ \pi_{2n+1}(z) &= \frac{z}{4} \left[ \left(1 + \frac{1}{s}\right) \pi_{2n}^{1/2, -3/2}(z) - \frac{3}{s} \pi_{2n}^{3/2, -3/2}(z) \right]. \end{cases} \quad (4.4)$$

<sup>9</sup>When  $s = \infty$ , it is understood that  $(s - (2k + 2))/s = 1$ .

To be able to write down an explicit expression for  $\mathbf{K}_N$  we shall need the weighted versions of the skew orthogonal polynomials defined by

$$\tilde{\pi}_n(z) := \pi_n(z) \max\{1, |z|\}^{-s}.$$

Then according to Theorem 1.4, the entries of  $\mathbf{K}_N$  are, when  $N = 2J$  is even,

$$\left\{ \begin{array}{l} \mathbf{K}_{2J}^{(1,1)}(u, v) := \varkappa_{2J}(u, v) = 2 \sum_{j=0}^{J-1} [\tilde{\pi}_{2j}(u)\tilde{\pi}_{2j+1}(v) - \tilde{\pi}_{2j}(v)\tilde{\pi}_{2j+1}(u)] \\ \mathbf{K}_{2J}^{(1,2)}(u, v) := \varkappa_{2J}\epsilon(u, v) = 2 \sum_{j=0}^{J-1} [\tilde{\pi}_{2j}(u)\epsilon\tilde{\pi}_{2j+1}(v) - \epsilon\tilde{\pi}_{2j}(v)\tilde{\pi}_{2j+1}(u)] \\ \mathbf{K}_{2J}^{(2,2)}(u, v) := \epsilon\varkappa_{2J}\epsilon(u, v) + \frac{1}{2} \operatorname{sgn}(u - v) \\ \qquad \qquad \qquad = 2 \sum_{j=0}^{J-1} [\epsilon\tilde{\pi}_{2j}(u)\epsilon\tilde{\pi}_{2j+1}(v) - \epsilon\tilde{\pi}_{2j}(v)\epsilon\tilde{\pi}_{2j+1}(u)] + \frac{1}{2} \operatorname{sgn}(u - v) \end{array} \right. \quad (4.5)$$

We introduce this new notation for the matrix entries, because when  $N = 2J + 1$  is odd, the entries are not given as simply as in Theorem 1.4. However, in this situation, the entries of  $\mathbf{K}_N$  can be computed from [36] or [14] to be

$$\left\{ \begin{array}{l} \mathbf{K}_{2J+1}^{(1,1)}(u, v) := \mathbf{K}_{2J}^{(1,1)}(u, v) - 2 \sum_{j=0}^{J-1} \frac{s_{2j}}{s_{2J}} [\tilde{\pi}_{2j}(u)\tilde{\pi}_{2j+1}(v) - \tilde{\pi}_{2j}(v)\tilde{\pi}_{2j+1}(u)] \\ \mathbf{K}_{2J+1}^{(1,2)}(u, v) := \mathbf{K}_{2J}^{(1,2)}(u, v) - 2 \sum_{j=0}^{J-1} \frac{s_{2j}}{s_{2J}} [\tilde{\pi}_{2j}(u)\epsilon\tilde{\pi}_{2j+1}(v) - \epsilon\tilde{\pi}_{2j}(v)\tilde{\pi}_{2j+1}(u)] \\ \qquad \qquad \qquad + \frac{\tilde{\pi}_{2J}(u)\chi_{\mathbb{R}}(v)}{s_{2J}} \\ \mathbf{K}_{2J+1}^{(2,2)}(u, v) := \mathbf{K}_{2J}^{(2,2)}(u, v) - 2 \sum_{j=0}^{J-1} \frac{s_{2j}}{s_{2J}} [\epsilon\tilde{\pi}_{2j}(u)\epsilon\tilde{\pi}_{2j+1}(v) - \epsilon\tilde{\pi}_{2j}(v)\epsilon\tilde{\pi}_{2j+1}(u)] \\ \qquad \qquad \qquad + \frac{\epsilon\tilde{\pi}_{2J}(u)\chi_{\mathbb{R}}(v) - \epsilon\tilde{\pi}_{2J}(v)\chi_{\mathbb{R}}(u)}{s_{2J}} \end{array} \right. , \quad (4.6)$$

where  $\chi_{\mathbb{R}}$  is the characteristic function of  $\mathbb{R}$ , and

$$s_k := \int_{\mathbb{R}} \tilde{\pi}_k(x) dx. \quad (4.7)$$

In general, expressions in (4.6) must contain terms corresponding to constants  $s_{2n+1}$  as well. However, it is easy to see from Theorem 4.1 that  $s_{2n+1} = 0$  for all  $n$ . Thus, only the terms corresponding to  $s_{2n}$  remain.

**Lemma 4.4.** *It holds that*

$$s_{2n} = 2 \frac{\Gamma\left(\frac{s+2}{2}\right) \Gamma\left(\frac{s-2n-1}{2}\right)}{\Gamma\left(\frac{s+1}{2}\right) \Gamma\left(\frac{s-2n}{2}\right)},$$

where it is understood that  $s_{2n} = 2$  when  $s = \infty$ .

## 5 A Family of Polynomials

As one can see from (4.4), all the skew orthogonal polynomials  $\{\pi_{2n}, \pi_{2n+1}\}$  can be expressed solely via even degree polynomials  $\{\pi_{2n}^{\alpha,\beta}\}$  for three pairs of parameters  $(\alpha, \beta)$ . Hence, to derive the results announced in Section 2, we shall study polynomials

$$P_n^{\alpha,\beta}(z) := \frac{1}{\Gamma(1+\alpha)\Gamma(1+\beta)} \sum_{k=0}^n \frac{\Gamma(k+1+\alpha)\Gamma(n-k+1+\beta)}{\Gamma(k+1)\Gamma(n-k+1)} z^k, \quad (5.1)$$

where  $\alpha, \beta \notin \{-1, -2, \dots\}$ . Clearly,  $\pi_{2n}^{\alpha,\beta}(z) = P_n^{\alpha,\beta}(z^2)$ .

### 5.1 Algebraic Properties of the Polynomials

The polynomials  $P_n^{\alpha,\beta}$  satisfy the following relations.

**Proposition 5.1.** *It holds that*

$$P_n^{\alpha,\beta}(z) = P_n^{\alpha,\beta-1}(z) + P_{n-1}^{\alpha,\beta}(z) \quad (5.2)$$

$$= z^n P_n^{\beta,\alpha}(1/z) \quad (5.3)$$

$$= \left[ \frac{n+\alpha}{n} z + \frac{n+\beta}{n} \right] P_{n-1}^{\alpha,\beta}(z) - \frac{n+\alpha+\beta}{n} z P_{n-2}^{\alpha,\beta}(z), \quad (5.4)$$

$$= \frac{\Gamma(n+2+\alpha+\beta)}{\Gamma(1+\alpha)\Gamma(1+\beta)\Gamma(n+1)} \int_C B_{\alpha,\beta}(t) (1-t+tz)^n dt, \quad (5.5)$$

where recurrence relations (5.4) hold for  $n \geq 2$  with  $P_0^{\alpha,\beta}(z) \equiv 1$ ,  $P_1^{\alpha,\beta}(z) = (1+\beta) + (1+\alpha)z$ ,  $C$  is the Pochhammer contour, and  $B_{\alpha,\beta}(t) := t^\alpha(1-t)^\beta / (1-e^{2\pi i\alpha})(1-e^{2\pi i\beta})$ .

Recall that the Pochhammer contour is a contour that winds clockwise around 1, then clockwise around another  $-1$ , then counterclockwise around 1, and then counterclockwise around  $-1$ .

The polynomials  $P_n^{\alpha,\beta}$  can be expressed via non-standard Jacobi polynomials.

**Proposition 5.2.** *It holds that*

$$P_n^{\alpha,\beta}(z) = (1-z)^n J_n^{-n-1-\alpha, -n-1-\beta} \left( \frac{z+1}{z-1} \right),$$

where  $J_n^{a,b}$  is the  $n$ -th Jacobi polynomial with parameters  $a, b$ .

For a large set of parameters the zeros of  $P_n^{\alpha,\beta}$  exhibit definite behavior with respect to the unit circle. Observe that due to (5.3), we only need to consider the case  $\alpha \geq \beta$ . Recall also that  $\alpha, \beta \notin \{-1, -2, \dots\}$ .

**Proposition 5.3.** (i)  $P_n^{\alpha,\beta}$  has a zero of order  $m$  at 1 if and only if  $n \geq m$  and  $m+1+\alpha+\beta = 0$  for some  $m \in \mathbb{N}$ .

(ii) The zeros of  $P_n^{\alpha,\beta}$  in  $\mathbb{C} \setminus \{1\}$  are simple.

(iii) Let  $\alpha > \beta$ . If either  $2+\alpha+\beta > 0$  or  $m+1+\alpha+\beta = 0$  for some  $m \in \mathbb{N}$ , then the zeros of  $P_n^{\alpha,\beta}$  are contained in  $\mathbb{D} \cup \{1\}$ .

(iv) Let  $\alpha = \beta$ . If  $3+2\alpha > 0$  or  $m+1+2\alpha = 0$  for some  $m$  even, then the zeros of  $P_n^{\alpha,\alpha}$  belong to  $\mathbb{T}$ .

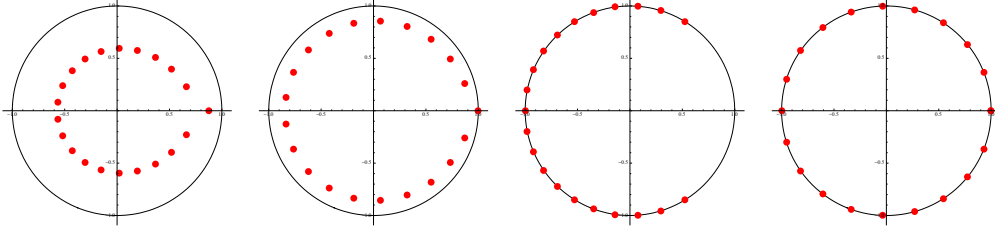

Figure 4: From left to right: the zeros of  $P_{21}^{1.5,-1.5}$ ,  $P_{21}^{-.6,-1.4}$ ,  $P_{21}^{11.5,11.5}$ , and  $P_{21}^{-1.5,-1.5}$ .

## 5.2 Asymptotic Properties of the Polynomials

The polynomials  $P_n^{\alpha,\beta}$  enjoy the following asymptotic properties.

**Theorem 5.4.** *Let  $(1-z)^{-(1+\gamma)}$  be the branch holomorphic in  $\mathbb{C} \setminus [1, \infty)$  and positive for  $z \in (-\infty, 1)$ . Then as  $n \rightarrow \infty$ ,*

$$\left| \frac{P_n^{\alpha,\beta}(z)}{P_n^{\alpha,\beta}(0)} - \frac{1}{(1-z)^{1+\alpha}} \right| = \frac{o(1)}{|1-z|}, \quad (5.6)$$

where  $o(1)$  holds uniformly in  $\overline{\mathbb{D}}$  when  $\alpha < 0$  and  $\beta > 0$ , and in  $\mathbb{D}$  otherwise. Furthermore,

$$\left| \frac{1}{z^n} \frac{P_n^{\alpha,\beta}(z)}{P_n^{\beta,\alpha}(0)} - \frac{1}{(1-1/z)^{1+\beta}} \right| = \frac{o(1)}{|1-1/z|}, \quad (5.7)$$

where  $o(1)$  holds uniformly in  $\overline{\mathbb{O}}$  when  $\alpha > 0$  and  $\beta < 0$ , and in  $\mathbb{O}$  otherwise.

Observe that

$$P_n^{\alpha,\beta}(0) = \frac{\Gamma(n+1+\beta)}{\Gamma(1+\beta)\Gamma(n+1)} = (1+o_n(1)) \frac{(n+1)^\beta}{\Gamma(1+\beta)}$$

by the properties of the Gamma function.

When  $\zeta + z/n \in \overline{\mathbb{O}}$ , it readily follows from (5.7), the maximum modulus principle, and normal family argument that the following corollary takes place.

**Corollary 5.5.** *Let  $\zeta \in \mathbb{T} \setminus \{1\}$ ,  $\alpha > 0$ , and  $\beta < 0$ . Then*

$$\lim_{n \rightarrow \infty} \frac{\Gamma(1+\alpha)}{(n+1)^\alpha} \left( \zeta + \frac{z}{n} \right)^{-n} P_n^{\alpha,\beta} \left( \zeta + \frac{z}{n} \right) = (1-\bar{\zeta})^{-1-\beta}$$

locally uniformly in  $\mathbb{C}$ .

It is obvious from the previous results that the point 1 is a special point for polynomials  $P_n^{\alpha,\beta}$ . To describe the behavior of the polynomials there we need the following definition:

$$M_{\alpha,\beta}(z) := \frac{\Gamma(1+\gamma)}{\Gamma(1+\alpha)} \sum_{n=0}^{\infty} \frac{\Gamma(n+1+\alpha)}{\Gamma(n+1+\gamma)} \frac{z^n}{n!}, \quad \gamma := 1+\alpha+\beta \notin \{-1, -2, \dots\}, \quad (5.8)$$

which is a confluent hypergeometric function with parameters  $\alpha, \gamma$ .

**Proposition 5.6.** *If  $\gamma = 1 + \alpha + \beta \notin \{-1, -2, \dots\}$ , then as  $n \rightarrow \infty$ ,*

$$P_n^{\alpha, \beta} \left( 1 + \frac{z}{n} \right) = (1 + o_n(1)) \frac{\Gamma(n+1+\gamma)}{\Gamma(1+\gamma)\Gamma(n+1)} M_{\alpha, \beta}(z) \quad (5.9)$$

locally uniformly in  $\mathbb{C}$ , where  $o_n(1) = 0$  when  $z = 0$ .

### 5.3 Asymptotic Properties of the Sums away from the Unit Circle

As apparent from (4.4) –(4.6), the main focus of this work is the asymptotic behavior of the sums

$$K_N^{\alpha_1, \beta_1, \alpha_2, \beta_2}(z, w) := \sum_{n=0}^{N-1} P_n^{\alpha_1, \beta_1}(z) P_n^{\alpha_2, \beta_2}(w). \quad (5.10)$$

Properly renormalized, these sums converge locally uniformly in  $\mathbb{D} \times \mathbb{D}$  and  $\mathbb{O} \times \mathbb{O}$ . To state the results, we shall need the following notation. For  $\beta_1 + \beta_2 + 1 < 0$  set  $\Lambda_{\beta_1, \beta_2}(\zeta)$  to be

$$\begin{cases} \frac{\Gamma(-\beta_1 - \beta_2 - 1)}{\Gamma(-\beta_1)\Gamma(-\beta_2)} [{}_2F_1(1, 1 + \beta_1; -\beta_2; \bar{\zeta}) + {}_2F_1(1, 1 + \beta_2; -\beta_1; \zeta) - 1], & \beta_1, \beta_2 \notin \mathbb{Z}_+, \\ \frac{\Gamma(-\beta_1 - \beta_2 - 1)}{\Gamma(-\beta_2)\Gamma(1 + \beta_2)} [\zeta^{1 + \beta_1} {}_2F_1(1, 2 + \beta_1 + \beta_2; 1; \zeta)], & \beta_1 \in \mathbb{Z}_+, \\ \frac{\Gamma(-\beta_1 - \beta_2 - 1)}{\Gamma(-\beta_2)\Gamma(1 + \beta_2)} [\bar{\zeta}^{1 + \beta_2} {}_2F_1(1, 2 + \beta_1 + \beta_2; 1; \bar{\zeta})], & \beta_2 \in \mathbb{Z}_+, \end{cases}$$

where

$${}_2F_1(a, b; c; z) := \frac{\Gamma(c)}{\Gamma(a)\Gamma(b)} \sum_{n=0}^{\infty} \frac{\Gamma(n+a)\Gamma(n+b)}{\Gamma(n+c)\Gamma(n+1)} z^n, \quad a, b, c \notin \mathbb{Z}_-. \quad (5.11)$$

The function  $\Lambda_{\beta_1, \beta_2}$  is continuous on  $\mathbb{T} \setminus \{-1\}$  with an integrable singularity at 1 when  $\beta_1 + \beta_2 + 1 \geq -1$  [13, Sec. 15.4] and is continuous on the whole circle when  $\beta_1 + \beta_2 + 1 < -1$ . It can be verified that the Fourier series corresponding to  $\Lambda_{\beta_1, \beta_2}$  is given by

$$\frac{\Gamma(-\beta_1 - \beta_2 - 1)}{\Gamma(1 + \beta_1)\Gamma(1 + \beta_2)} \left[ \sum_{m=0}^{\infty} \frac{\Gamma(1 + \beta_1)}{\Gamma(-\beta_2)} \frac{\Gamma(m+1 + \beta_2)}{\Gamma(m - \beta_1)} \zeta^m + \sum_{m=1}^{\infty} \frac{\Gamma(1 + \beta_2)}{\Gamma(-\beta_1)} \frac{\Gamma(m+1 + \beta_1)}{\Gamma(m - \beta_2)} \bar{\zeta}^m \right], \quad (5.12)$$

where it is understood that the terms containing  $\Gamma(-\beta_j)$  are zero when  $\beta_j$  is a non-negative integer.

**Theorem 5.7.** *It holds that*

$$\lim_{N \rightarrow \infty} K_N^{\alpha_1, \beta_1, \alpha_2, \beta_2}(0, 0) = \begin{cases} \pm\infty, & \beta_1 + \beta_2 + 1 \geq 0, \\ \frac{\Gamma(-\beta_1 - \beta_2 - 1)}{\Gamma(-\beta_1)\Gamma(-\beta_2)}, & \beta_1 + \beta_2 + 1 < 0, \end{cases} \quad (5.13)$$

where the sign in the first case is the same as the sign of  $\Gamma(1 + \beta_1)\Gamma(1 + \beta_2)$ . Moreover, we have that

$$\lim_{N \rightarrow \infty} \frac{K_N^{\alpha_1, \beta_1, \alpha_2, \beta_2}(z, w)}{K_N^{\alpha_1, \beta_1, \alpha_2, \beta_2}(0, 0)} = \frac{1}{(1-z)^{1+\alpha_1}(1-w)^{1+\alpha_2}} \quad (5.14)$$

locally uniformly in  $\mathbb{D} \times \mathbb{D}$  when  $\beta_1 + \beta_2 + 1 \geq 0$ , and

$$\lim_{N \rightarrow \infty} K_N^{\alpha_1, \beta_1, \alpha_2, \beta_2}(z, w) = \frac{1}{2\pi} \int_{\mathbb{T}} \frac{\Lambda_{\beta_1, \beta_2}(\zeta) |d\zeta|}{(1-z\bar{\zeta})^{1+\alpha_1}(1-w\zeta)^{1+\alpha_2}} \quad (5.15)$$

locally uniformly in  $\mathbb{D} \times \mathbb{D}$  when  $\beta_1 + \beta_2 + 1 < 0$ . Finally, it holds that

$$\lim_{N \rightarrow \infty} \frac{K_N^{\alpha_1, \beta_1, \alpha_2, \beta_2}(z, w)}{N^{\alpha_1 + \alpha_2} (zw)^N} = \frac{1}{\Gamma(1 + \alpha_1) \Gamma(1 + \alpha_2)} \frac{1}{(zw - 1)(1 - 1/z)^{1 + \beta_1} (1 - 1/w)^{1 + \beta_2}} \quad (5.16)$$

uniformly on closed subsets of  $\mathbb{O} \times \mathbb{O}$ .

## 5.4 Asymptotic Properties of the Sums on the Unit Circle

Theorem 5.7 shows that non-trivial scaling limits of the sums  $K_N^{\alpha_1, \beta_1, \alpha_2, \beta_2}$  can appear only on  $\mathbb{T} \times \mathbb{T}$ . To derive such limits we need rather precise knowledge of the behavior of the polynomials on the unit circle. Hence, in the light of (5.7), we shall only consider parameters satisfying  $\alpha > 0$  and  $\beta < 0$ . To describe the aforementioned scaling limits, set

$$E_\gamma(\tau) := (1 + \gamma) \int_0^1 x^\gamma e^{\tau x} dx, \quad \gamma > -1, \quad (5.17)$$

where the normalization is chosen so  $E_\gamma(0) = 1$ . Clearly, it holds that  $E_0(\tau) := \frac{e^\tau - 1}{\tau}$  and  $E'_\gamma(\tau) = \frac{\gamma + 1}{\gamma + 2} E_{\gamma+1}(\tau)$ .

**Theorem 5.8.** *Let  $\alpha_i > 0$  and  $\beta_i < 0$ ,  $i \in \{1, 2\}$ . Then for every  $\zeta \in \mathbb{T} \setminus \{1\}$  it holds that*

$$K_N^{\alpha_1, \beta_1, \alpha_2, \beta_2}(\zeta, \bar{\zeta}) = \left[ \frac{(1 - \bar{\zeta})^{-1 - \beta_1} (1 - \zeta)^{-1 - \beta_2}}{1 + \alpha_1 + \alpha_2} + o_N(1) \right] \frac{\Gamma(N + 1 + \alpha_1 + \alpha_2)}{\Gamma(1 + \alpha_1) \Gamma(1 + \alpha_2) \Gamma(N)}$$

as  $N \rightarrow \infty$  and

$$\lim_{N \rightarrow \infty} \frac{K_N^{\alpha_1, \beta_1, \alpha_2, \beta_2}(\zeta + \frac{a_1}{N}, \bar{\zeta} + \frac{\bar{a}_2}{N})}{K_N^{\alpha_1, \beta_1, \alpha_2, \beta_2}(\zeta, \bar{\zeta})} = E_{\alpha_1 + \alpha_2}(a_1 \bar{\zeta} + \bar{a}_2 \zeta),$$

uniformly for  $a_1, a_2$  on compact subsets of  $\mathbb{C}$ .

The scaling limit at 1 is no longer described by (5.17), but rather by

$$E_{\alpha_1, \beta_1, \alpha_2, \beta_2}(\tau_1, \tau_2) := (1 + \gamma) \int_0^1 x^\gamma M_{\alpha_1, \beta_1}(\tau_1 x) M_{\alpha_2, \beta_2}(\tau_2 x) dx, \quad (5.18)$$

where  $\gamma := 2 + \alpha_1 + \beta_1 + \alpha_2 + \beta_2 > -1$  and  $M_{\alpha, \beta}$  was defined in (5.8).

**Theorem 5.9.** *Let  $\alpha_i > 0$  and  $\beta_i < 0$ ,  $i \in \{1, 2\}$ . If  $\gamma = 2 + \alpha_1 + \beta_1 + \alpha_2 + \beta_2 > -1$ , then*

$$K_N^{\alpha_1, \beta_1, \alpha_2, \beta_2}(1, 1) = \frac{1 + o_N(1)}{\Gamma(2 + \alpha_1 + \beta_1) \Gamma(2 + \alpha_2 + \beta_2)} \frac{1}{1 + \gamma} \frac{\Gamma(N + 1 + \gamma)}{\Gamma(N)}$$

as  $N \rightarrow \infty$  and

$$\lim_{N \rightarrow \infty} \frac{K_N^{\alpha_1, \beta_1, \alpha_2, \beta_2}(1 + \frac{a_1}{N}, 1 + \frac{a_2}{N})}{K_N^{\alpha_1, \beta_1, \alpha_2, \beta_2}(1, 1)} = E_{\alpha_1, \beta_1, \alpha_2, \beta_2}(a_1, a_2) \quad (5.19)$$

uniformly for  $a_1, a_2$  on compact subsets of  $\mathbb{C}$ .

## 6 Proofs

### 6.1 Proof of Theorem 4.3

The following lemma is needed both for the proofs of Theorem 4.3 and Lemma 4.4.

**Lemma 6.1.** *Let  $a, b \in \mathbb{R}$  with  $b \notin \{0, -1, -2, \dots\}$ . Then,*

$$\begin{aligned} \frac{1}{\Gamma(b)\Gamma(a)} \sum_{k=0}^n \frac{\Gamma(k+a)\Gamma(n-k+b)}{\Gamma(k+1)\Gamma(n-k+1)} \left\{ \prod_{j=1}^k \frac{j-b}{j+a-1} \right\} \frac{1}{x-k+b} \\ = \frac{x(x-1)\cdots(x-n+1)}{(x+b)(x+b-1)\cdots(x+b-n)}. \end{aligned}$$

*Proof.* Since

$$\frac{\Gamma(k+a)}{\Gamma(a)} = \prod_{j=1}^k \frac{1}{j+a-1},$$

it suffices to prove that

$$\frac{1}{\Gamma(b)} \sum_{k=0}^n \frac{\Gamma(n-k+b)}{\Gamma(k+1)\Gamma(n-k+1)} \left\{ \prod_{j=1}^k (j-b) \right\} \frac{1}{x-k+b} = \frac{x(x-1)\cdots(x-n+1)}{(x+b)(x+b-1)\cdots(x+b-n)}.$$

The coefficient of  $(x-k+b)^{-1}$  in the partial fractions decomposition of the rational function on the right hand side is

$$\begin{aligned} \frac{x(x-1)\cdots(x-n+1)}{(x+b)(x+b-1)\cdots(x+b-n)} (x+b-k) \Big|_{x=k-b} \\ = \left( \prod_{j=0}^{k-1} (k-b-j) \prod_{\ell=k}^{n-1} (k-b-\ell) \right) / \left( \prod_{j=0}^{k-1} (k-j) \prod_{\ell=k+1}^n (k-\ell) \right) \\ = \left( \left\{ \prod_{j=1}^k (j-b) \right\} (-1)^{n-k} \prod_{\ell=0}^{n-k-1} (b+\ell) \right) / \left( \Gamma(k+1) (-1)^{n-k} \Gamma(n-k+1) \right) \\ = \left( \left\{ \prod_{j=1}^k (j-b) \right\} \Gamma(n-k+b) \right) / \left( \Gamma(b)\Gamma(k+1)\Gamma(n-k+1) \right), \end{aligned}$$

which proves the lemma.  $\square$

*Proof of Theorem 4.3.* For the moment, let us write  $\pi_{2n} = \Gamma(\alpha+1)\Gamma(\beta+1)\pi_{2n}^{\alpha,\beta}$  and  $\pi_{2n+1} = \Gamma(-\beta-1)\Gamma(\beta+1)\pi_{2n+1}^{\beta}$ . Then

$$\begin{aligned} \langle \pi_{2n}(z) | z^{2m+1} \rangle^{\alpha,\beta} &= \sum_{k=0}^n \frac{\Gamma(k+\alpha+1)\Gamma(n-k+\beta+1)}{\Gamma(k+1)\Gamma(n-k+1)} \langle z^{2k} | z^{2m+1} \rangle^{\alpha,\beta} \\ &= C_m \sum_{k=0}^n \frac{\Gamma(k+\alpha+1)\Gamma(n-k+\beta+1)}{\Gamma(k+1)\Gamma(n-k+1)} \left\{ \prod_{j=1}^k \frac{j-1-\beta}{j+\alpha} \right\} \frac{1}{m-k+1+\beta}, \end{aligned}$$

which by setting  $a = \alpha + 1$  and  $b = \beta + 1$  in Lemma 6.1, is equal to 0 for  $m = 0, 1, \dots, n$ . Since  $\pi_{2m+1}^{\alpha, \beta}$  is odd of degree  $2m + 1$ , we have  $\langle \pi_{2n}^{\alpha, \beta} | \pi_{2m+1}^{\alpha, \beta} \rangle^{\alpha, \beta} = 0$  for these values of  $m$ .

Similarly, looking at

$$\begin{aligned} \langle z^{2m} | \pi_{2n+1}(z) \rangle^{\alpha, \beta} &= \sum_{k=0}^n \frac{\Gamma(k + \beta + 2) \Gamma(n - k - \beta - 1)}{\Gamma(k + 1) \Gamma(n - k + 1) C_k} \langle z^{2m} | z^{2k+1} \rangle^{\alpha, \beta} \\ &= - \left\{ \prod_{j=1}^m \frac{j - 1 - \beta}{j + \alpha} \right\} \sum_{k=0}^n \frac{\Gamma(k + \beta + 2) \Gamma(n - k - \beta - 1)}{\Gamma(k + 1) \Gamma(n - k + 1)} \frac{1}{m - k - 1 - \beta} \\ &= -(\beta + 1) \left\{ \prod_{j=1}^m \frac{j - 1 - \beta}{j + \alpha} \right\} \\ &\quad \times \sum_{k=0}^n \frac{\Gamma(k + \beta + 1) \Gamma(n - k - \beta - 1)}{\Gamma(k + 1) \Gamma(n - k + 1)} \left\{ \frac{k + \beta + 1}{\beta + 1} \right\} \frac{1}{m - k - 1 - \beta}, \end{aligned}$$

which by Lemma 6.1 is equal to 0 for  $m = 0, 1, \dots, n-1$  by setting  $a = \beta + 1$  and  $b = -\beta - 1$ .

Turning to  $\langle \pi_{2n}^{\alpha, \beta} | \pi_{2n+1}^{\beta} \rangle^{\alpha, \beta}$ ,

$$\begin{aligned} \langle \pi_{2n}^{\alpha, \beta} | \pi_{2n+1}^{\beta} \rangle^{\alpha, \beta} &= \frac{1}{\Gamma(\alpha + 1) \Gamma(\beta + 1)} \sum_{k=0}^n \frac{\Gamma(k + \alpha + 1) \Gamma(n - k + \beta + 1)}{\Gamma(k + 1) \Gamma(n - k + 1)} \langle z^{2k} | \pi_{2n+1}^{\beta}(z) \rangle^{\alpha, \beta} \\ &= \frac{\Gamma(n + \alpha + 1)}{\Gamma(\alpha + 1) \Gamma(n + 1)} \langle z^{2n} | \pi_{2n+1}^{\beta}(z) \rangle^{\alpha, \beta} \\ &= - \frac{\Gamma(n + \alpha + 1) (\beta + 1)}{\Gamma(\alpha + 1) \Gamma(n + 1)} \left\{ \prod_{j=1}^n \frac{j - 1 - \beta}{j + \alpha} \right\} \frac{1}{\Gamma(-\beta - 1) \Gamma(\beta + 1)} \\ &\quad \times \sum_{k=0}^n \frac{\Gamma(k + \beta + 1) \Gamma(n - k - \beta - 1)}{\Gamma(k + 1) \Gamma(n - k + 1)} \left\{ \frac{k + \beta + 1}{\beta + 1} \right\} \frac{1}{n - k - 1 - \beta} \\ &= - \frac{(\beta + 1)}{\Gamma(n + 1)} \left\{ \prod_{j=1}^n (j - 1 - \beta) \right\} \Gamma(n + 1) \prod_{j=0}^n \frac{1}{n - \beta - j - 1} = 1, \end{aligned}$$

where again, we use Lemma 6.1 with  $a = \beta + 1$  and  $b = -\beta - 1$ .  $\square$

*Proof of Lemma 4.4.* It holds that

$$\int_{\mathbb{R}} x^{2k} \max\{1, |x|\}^{-s} dx = 2 \int_0^1 x^{2k} dx + 2 \int_1^{\infty} x^{2k-s} dx = \frac{2s}{(2k + 1)(s - 2k - 1)}.$$

Then it follows from Theorem 4.1 and Lemma 6.1 that

$$\begin{aligned} s_{2n} &= \frac{s}{\Gamma(1/2) \Gamma(1/2)} \sum_{k=0}^n \frac{\Gamma(k + 1/2) \Gamma(n - k + 1/2)}{\Gamma(k + 1) \Gamma(n - k + 1)} \left\{ \prod_{j=1}^k \frac{j - 1/2}{j + 1/2 - 1} \right\} \frac{1}{s/2 - 1 - k + 1/2} \\ &= 2 \frac{(s/2)(s/2 - 1)(s/2 - 2) \cdots (s/2 - n)}{(s/2 - 1/2)(s/2 - 1/2 - 1) \cdots (s/2 - 1/2 - n)} = 2 \frac{\Gamma(\frac{s+2}{2}) \Gamma(\frac{s-2n-1}{2})}{\Gamma(\frac{s+1}{2}) \Gamma(\frac{s-2n}{2})} \end{aligned}$$

and the case  $s = \infty$  follows by taking the limit.  $\square$



## 6.2 Proofs of Propositions 5.1—5.3

*Proof of Proposition 5.1.* By the very definition the difference  $\Gamma(1 + \alpha)\Gamma(1 + \beta)(P_n^{\alpha, \beta}(z) - P_{n-1}^{\alpha, \beta}(z))$  is equal to

$$\begin{aligned} & \frac{\Gamma(n+1+\alpha)}{\Gamma(n+1)} \frac{\Gamma(\beta+1)}{\Gamma(1)} z^n + \sum_{k=0}^{n-1} \frac{\Gamma(k+1+\alpha)}{\Gamma(k+1)} \left( \frac{\Gamma(n-k+1+\beta)}{\Gamma(n-k+1)} - \frac{\Gamma(n-k+\beta)}{\Gamma(n-k)} \right) z^k \\ &= \frac{\Gamma(n+\alpha)}{\Gamma(n+1)} \frac{\Gamma(\beta+1)}{\Gamma(1)} z^n + \beta \sum_{k=0}^{n-1} \frac{\Gamma(k+1+\alpha)}{\Gamma(k+1)} \frac{\Gamma(n-k+\beta)}{\Gamma(n-k+1)} z^k \\ &= \beta \sum_{k=0}^n \frac{\Gamma(k+1+\alpha)}{\Gamma(k+1)} \frac{\Gamma(n-k+\beta)}{\Gamma(n-k+1)} z^k = \beta \Gamma(1+\alpha)\Gamma(\beta) P_n^{\alpha, \beta-1}(z), \end{aligned}$$

which establishes (5.2). Relation (5.3) is rather obvious.

Consider the right-hand side of (5.4) multiplied by  $\Gamma(1 + \alpha)\Gamma(1 + \beta)$ . The coefficient of  $z^n$  is

$$\frac{n + \alpha}{n} \frac{\Gamma(n + \alpha)}{\Gamma(n)} \frac{\Gamma(1 + \beta)}{\Gamma(1)} = \frac{\Gamma(n + 1 + \alpha)}{\Gamma(n + 1)} \frac{\Gamma(1 + \beta)}{\Gamma(1)},$$

the constant coefficient is

$$\frac{n + \beta}{n} \frac{\Gamma(1 + \alpha)}{\Gamma(1)} \frac{\Gamma(n + \beta)}{\Gamma(n)} = \frac{\Gamma(1 + \alpha)}{\Gamma(1)} \frac{\Gamma(n + 1 + \beta)}{\Gamma(n + 1)},$$

and the coefficient of  $z^k$ ,  $k \in \{1, \dots, n-1\}$ , is

$$\begin{aligned} & \frac{n + \alpha}{n} \frac{\Gamma(k + \alpha)}{\Gamma(k)} \frac{\Gamma(n - k + 1 + \beta)}{\Gamma(n - k + 1)} + \frac{n + \beta}{n} \frac{\Gamma(k + 1 + \alpha)}{\Gamma(k + 1)} \frac{\Gamma(n - k + \beta)}{\Gamma(n - k)} \\ & \quad - \frac{n + \alpha + \beta}{n} \frac{\Gamma(k + \alpha)}{\Gamma(k)} \frac{\Gamma(n - k + \beta)}{\Gamma(n - k)}, \end{aligned}$$

which is equal to

$$\begin{aligned} & \frac{\Gamma(k + \alpha)}{\Gamma(k)} \frac{\Gamma(n - k + \beta)}{\Gamma(n - k)} \left[ \frac{n + \alpha}{n} \frac{n - k + \beta}{n - k} + \frac{n + \beta}{n} \frac{n + \alpha}{k} - \frac{n + \alpha + \beta}{n} \right] \\ &= \frac{\Gamma(k + \alpha)}{\Gamma(k)} \frac{\Gamma(n - k + \beta)}{\Gamma(n - k)} \frac{\beta k + \alpha(n - k) + \alpha\beta + k(n - k)}{k(n - k)} \\ &= \frac{\Gamma(k + 1 + \alpha)}{\Gamma(k + 1)} \frac{\Gamma(n - k + 1 + \beta)}{\Gamma(n - k + 1)}. \end{aligned}$$

Finally, recall that for any values  $u, v$  it holds that

$$\frac{\Gamma(u)\Gamma(v)}{\Gamma(u+v)} = B(u, v) = \frac{1}{(1 - e^{2\pi i u})(1 - e^{2\pi i v})} \int_C t^{u-1}(1-t)^{v-1} dt, \quad (6.1)$$

where  $C$  is the Pochhammer contour. Then

$$\begin{aligned} P_n^{\alpha, \beta}(z) &= \frac{\Gamma(n+2+\alpha+\beta)}{\Gamma(1+\alpha)\Gamma(1+\beta)\Gamma(n+1)} \sum_{k=0}^n B(k+1+\alpha, n-k+1+\beta) \binom{n}{k} z^k \\ &= \frac{\Gamma(n+2+\alpha+\beta)}{(1 - e^{2\pi i \alpha})(1 - e^{2\pi i \beta})\Gamma(n+1)} \int_C \sum_{k=0}^n \binom{n}{k} (1-t)^{n-k+\beta} t^{k+\alpha} z^k dt, \end{aligned}$$

from which (5.5) easily follows.  $\square$

*Proof of Proposition 5.2.* By definition,  $(1-z)^n J_n^{-n-1-\alpha, -n-1-\beta} \left( \frac{z+1}{z-1} \right)$  is equal to

$$\frac{(1-z)^n}{n!} \frac{\Gamma(-\alpha)}{\Gamma(-n-1-\alpha-\beta)} \sum_{m=0}^n \binom{n}{m} \frac{\Gamma(-n-1+m-\alpha-\beta)}{\Gamma(-n+m-\alpha)} \frac{1}{(z-1)^m},$$

which can be rewritten as

$$(-1)^n \frac{\Gamma(-\alpha)}{\Gamma(-n-1-\alpha-\beta)} \sum_{j=0}^n \frac{1}{j!(n-j)!} \frac{\Gamma(-j-1-\alpha-\beta)}{\Gamma(-j-\alpha)} (z-1)^j.$$

Expanding  $(z-1)^j$  into the powers of  $z$ , we get that the above polynomial can be expressed as

$$(-1)^n \sum_{k=0}^n \left( \sum_{j=k}^n \frac{(-1)^{j-k}}{(n-j)!(j-k)!} \frac{\Gamma(-j-1-\alpha-\beta)}{\Gamma(-n-1-\alpha-\beta)} \frac{\Gamma(-\alpha)}{\Gamma(-j-\alpha)} \right) \frac{z^k}{\Gamma(k+1)}$$

and respectively as

$$\sum_{k=0}^n \left( \sum_{j=k}^n (-1)^{j-k} \binom{n-k}{j-k} \frac{\Gamma(j+1+\alpha)}{\Gamma(1+\alpha)} \frac{\Gamma(n+2+\alpha+\beta)}{\Gamma(j+2+\alpha+\beta)} \right) \frac{z^k}{\Gamma(k+1)\Gamma(n-k+1)}.$$

Thus, the claim of the proposition will follow if we show that

$$\sum_{m=0}^M (-1)^m \binom{M}{m} \frac{\Gamma(m+x)}{\Gamma(m+x+y)} = \frac{\Gamma(x)}{\Gamma(y)} \frac{\Gamma(M+y)}{\Gamma(M+x+y)}, \quad (6.2)$$

where  $M := n-k$ ,  $m := j-k$ ,  $x = k+1+\alpha$ , and  $y = 1+\beta$ . We prove (6.2) by induction. As the left-hand side of (6.2) for  $M+1$  is equal to

$$\begin{aligned} \sum_{m=0}^M (-1)^m \binom{M}{m} \frac{\Gamma(m+x)}{\Gamma(m+x+y)} + \sum_{m=1}^{M+1} (-1)^m \binom{M}{m-1} \frac{\Gamma(m+x)}{\Gamma(m+x+y)} \\ = \sum_{m=0}^M (-1)^m \binom{M}{m} \left( \frac{\Gamma(m+x)}{\Gamma(m+x+y)} - \frac{\Gamma(m+1+x)}{\Gamma(m+1+x+y)} \right), \end{aligned}$$

the claim follows from the inductive hypothesis and since

$$\frac{\Gamma(x)}{\Gamma(y)} \frac{\Gamma(M+y)}{\Gamma(M+x+y)} - \frac{\Gamma(1+x)}{\Gamma(y)} \frac{\Gamma(M+y)}{\Gamma(M+1+x+y)} = \frac{\Gamma(x)}{\Gamma(y)} \frac{\Gamma(M+1+y)}{\Gamma(M+1+x+y)}. \quad \square$$

*Proof of Proposition 5.3.* We start by showing that

$$P_m^{\alpha, \beta}(z) = \frac{\Gamma(m+1+\alpha)}{\Gamma(m+1)\Gamma(1+\alpha)} (z-1)^m \quad (6.3)$$

if and only if  $m+1+\alpha+\beta=0$ . Indeed, if (6.3) takes place, it is enough to compare the coefficient next to  $z^{m-1}$  in (6.3) and (5.1) to deduce that  $m+1+\alpha+\beta=0$ . To prove the claim in the other direction, assume that (6.3) holds for some fixed  $m$  and all

$\alpha, \beta \notin \{-1, -2, \dots\}$  such that  $m + 1 + \alpha + \beta = 0$ . Then it follows from recurrence formula (5.4) that

$$P_{m+1}^{\alpha, \beta}(z) = \left[ \frac{m+1+\alpha}{m+1}z + \frac{m+1+\beta}{m+1} \right] P_m^{\alpha, \beta}(z). \quad (6.4)$$

Now, take  $\alpha, \beta$  such that  $m + 2 + \alpha + \beta = 0$ . Then (6.3) and (6.4) hold with  $\beta$  replaced by  $\beta + 1$ . Hence, we get from (5.2) that

$$P_{m+1}^{\alpha, \beta}(z) = \left[ \frac{m+1+\alpha}{m+1}z + \frac{\beta+1}{m+1} \right] P_m^{\alpha, \beta+1}(z) = \frac{\Gamma(m+2+\alpha)}{\Gamma(m+2)\Gamma(1+\alpha)}(z-1)^{m+1}.$$

Thus, to prove (6.3) in full generality it only remains to establish the base case  $m = 1$ , which follows easily since  $P_1^{\alpha, \beta}(z) = (1+\alpha)(z-1)$  when  $2 + \alpha + \beta = 0$ .

We just established in (6.3) and (6.4) that  $P_m^{\alpha, \beta}$  and  $P_{m+1}^{\alpha, \beta}$  vanish at 1 with order  $m$  whenever  $m + 1 + \alpha + \beta = 0$ . Recurrence relations (5.4) immediately yield that the same is true for all  $P_n^{\alpha, \beta}$ ,  $n \geq m$ . Reciprocally, assume that  $P_n^{\alpha, \beta}$  vanishes at 1 with order  $m$ . We can suppose that  $n > m$  as the case  $n = m$  is covered by (6.3). By Proposition 5.2, we get that

$$P_n^{\alpha, \beta}(z) = (1-z)^n \frac{(-1)^n}{2^n n!} J_n(x); \quad x = \frac{z+1}{z-1},$$

where  $J_n$  is a constant multiple of the Jacobi polynomial  $J_n^{-n-1-\alpha, -n-1-\beta}$ . Observe that the map  $z \mapsto (z+1)/(z-1)$  is conformal, maps 1 to  $\infty$  and sends the unit disk  $\mathbb{D}$  onto the left half-plane (the unit circle into the imaginary axis). In particular,  $P_n^{\alpha, \beta}$  vanishes at 1 with order  $m$  if and only if  $\deg(J_n) = n - m$ . According to the Rodrigues' formula for the Jacobi polynomials it holds that

$$\frac{d^n}{dx^n} \left\{ \frac{1}{(1-x)^{1+\alpha}(1+x)^{1+\beta}} \right\} = \frac{J_n(x)}{(1-x)^{n+1+\alpha}(1+x)^{n+1+\beta}}$$

and therefore

$$J_{n+1}(x) = (1-x^2)J'_n(x) + [(2n+2+\alpha+\beta)x + \alpha - \beta]J_n(x). \quad (6.5)$$

Particularly, it follows that  $\deg(J_{n+1}) = n + 1 - m$ . That is,  $P_{n+1}^{\alpha, \beta}$  vanishes at 1 with order  $m$  as well. Furthermore, recurrence formula (5.4) yields in this case that  $P_{n-1}^{\alpha, \beta}$  is divisible by  $(z-1)^m$ . Repeatedly applying (5.4), we obtain that  $P_m^{\alpha, \beta}$  must be a multiple of  $(z-1)^m$  too and therefore  $m + 1 + \alpha + \beta = 0$  by (6.3). This finishes the prove of the first claim of the proposition.

Proving the second claim of the proposition is tantamount to showing that the zeros of  $J_n$  are simple. To the contrary, assume that  $J_n$  has a zero, say  $x_0$ , of multiplicity  $k \geq 2$ . Observe that  $x_0 \neq \pm 1$  as otherwise  $P_n^{\alpha, \beta}$  would have to vanish at 0 or had a degree less than  $n$ , which contradicts the very definition of this polynomial. From our assumption,  $x_0$  is a zero of  $J'_n$  of multiplicity  $k - 1$  and therefore it is a zero of  $J_{n+1}$  of multiplicity exactly  $k - 1$  by (6.5). Then we can infer from (5.4) that  $J_{n-1}$  must vanish at  $x_0$  with order exactly  $k - 1$ . Further, using (6.5) with  $n$  replaced by  $n - 1$ , we get that  $J'_{n-1}$  has to vanish at  $x_0$  with the same order which is clearly impossible.

Now suppose  $\alpha > \beta$ . Assume that either  $2 + \alpha + \beta > 0$ , in which case set  $m = 0$ , or  $m + 1 + \alpha + \beta = 0$  for some  $m \in \mathbb{N}$ . Under these conditions we have that  $2m + 2 + \alpha + \beta > 0$  and  $\deg(J_n) = n - m$ ,  $n \geq m$ . Recall that the interior of the unit disk gets mapped into the

left half-plane and therefore we want to establish that this is where the zeros of  $J_n$  are. As  $J_m$  is a constant by (6.3), it holds that

$$J_{m+1}(x) = [(2m+2+\alpha+\beta)x + \alpha - \beta]J_m(x) \quad (6.6)$$

is of degree 1 and vanishes on the negative real axis. Denote by  $-x_i$  the zeros of  $J_n$ . Then for  $n \geq m+1$  we have that

$$(J_{n+1}/J_n)(x) = \sum \frac{1+xx_i}{x+x_i} + (n+m+2+\alpha+\beta)x + (\alpha-\beta). \quad (6.7)$$

It can be easily verified that the ratio  $J_{n+1}/J_n$  has strictly positive real part in the closed right half-plane when the numbers  $x_i$  have positive real parts. That is, if all the zeros of  $J_n$  belong to the left half-plane, then all the zeros of  $J_{n+1}$  belong to the left half-plane as well. The proof of the third claim of the proposition now follows from the principle of mathematical induction.

Finally, let  $\alpha = \beta$ . In this case  $J_{m+1}$  in (6.6) is a linear function vanishing at the origin. Furthermore, (6.7) implies that the ratio  $J_{n+1}/J_n$  has positive real part in the right half-plane and negative real part in the left half-plane when  $n+m+2+2\alpha \geq 0$  and  $x_i \in i\mathbb{R}$ . That is, if the zeros of  $J_n$  are on the imaginary axis so are the zeros of  $J_{n+1}$ . This finishes the proof of the proposition.  $\square$

### 6.3 Proofs of Theorem 5.4 and Proposition 5.6

For reasons of brevity, below we shall often employ the following notation:

$$c_x(\alpha) := \frac{\Gamma(x+1+\alpha)}{\Gamma(\alpha+1)\Gamma(x+1)}. \quad (6.8)$$

Using this notation we can write  $P_n^{\alpha,\beta}(z) = \sum_{k=0}^n c_k(\alpha)c_{n-k}(\beta)z^k$ . Since

$$\Gamma(x) = \sqrt{2\pi/x}(x/e)^x(1+O(1/x)) \quad \text{as } x \rightarrow \infty,$$

it holds that

$$\Gamma(\alpha+1)c_x(\alpha) = (x+1)^\alpha(1+O(1/x)) \quad \text{as } x \rightarrow \infty. \quad (6.9)$$

and respectively

$$B(\alpha_1, \alpha_2)c_n(\alpha_1)c_n(\alpha_2) = (1+O(1/n))c_n(\alpha_1 + \alpha_2), \quad (6.10)$$

where  $B(\alpha_1, \alpha_2)$  is the beta function; see (6.1).

We also employ the notation  $f(x) \sim g(x)$  as  $x \rightarrow \infty$  which means that  $g(x) \ll f(x) \ll g(x)$  where  $f(x) \ll_c g(x)$  stands for  $f(x) \leq A(c)g(x)$  and  $A(c)$  is a constant depending only on  $c$ .

The following simple lemma is needed for the proof of Theorem 5.4 and is an application of summation by parts.

**Lemma 6.2.** *Suppose  $\{a_k\}_{k=0}^\infty$  is a non-increasing sequence of positive numbers and let  $\{\{b_{k,m}\}_{k=0}^m\}_{m=0}^\infty$  be a collection of non-decreasing, non-negative sequences. Then*

$$\left| \sum_{k=0}^m a_k b_{k,m} z^k \right| \leq 4 \frac{a_0 b_{m,m}}{|1-z|}, \quad z \in \overline{\mathbb{D}}.$$

*Proof.* Define  $B_{k,m} := \sum_{j=0}^k b_{j,m} z^j$ . According to the summation by parts, it holds that

$$B_{k,m} = b_{k,m} \frac{1 - z^{k+1}}{1 - z} + \sum_{j=0}^{k-1} \frac{1 - z^{j+1}}{1 - z} (b_{j,m} - b_{j+1,m})$$

and consequently that

$$|B_{k,m}| \leq \frac{2b_{k,m}}{|1 - z|} + \frac{2}{|1 - z|} \sum_{k=0}^{k-1} (b_{j+1,m} - b_{j,m}) \leq \frac{4b_{k,m}}{|1 - z|} \leq \frac{4b_{m,m}}{|1 - z|}$$

for  $z \in \overline{\mathbb{D}}$ . Hence, applying summation by parts once more, we get that

$$\left| \sum_{k=0}^m a_k b_{k,m} z^k \right| = a_m |B_{m,m}| + \sum_{k=0}^{m-1} |B_{k,m}| (a_k - a_{k+1}) \leq 4 \frac{b_{m,m} a_0}{|1 - z|}. \quad \square$$

*Proof of Theorem 5.4.* Let  $c_k(\alpha)$  be defined by (6.8). The sequence  $\{c_k(\alpha)\}_{k=0}^{\infty}$  is positive and increasing when  $\alpha > 0$ . If  $\alpha < 0$ , let  $k_\alpha$  be the first integer such that  $k_\alpha + \alpha > -1$ . Then the numbers  $c_k(\alpha)$  have the same sign for all  $k \geq k_\alpha$  and the sequence  $\{c_k(\alpha)\}_{k=k_\alpha}^{\infty}$  is decreasing. Observe also that

$$(1 - z)^{-(1+\alpha)} = \sum_{k=0}^{\infty} c_k(\alpha) z^k,$$

where the series converges for all  $z \in \overline{\mathbb{D}} \setminus \{1\}$  when  $\alpha < 0$  by the virtue of Lemma 6.2. Further, put

$$d_{k,n} := \frac{\beta}{|\beta|} \left[ 1 - \frac{\Gamma(n+1)}{\Gamma(n+1+\beta)} \frac{\Gamma(n-k+1+\beta)}{\Gamma(n-k+1)} \right].$$

Then the sequences  $\{d_{k,n}\}_{k=0}^n$  are positive and increasing for all  $n$  large enough, and bounded above by 1 when  $\beta > 0$ . Moreover, it holds that  $d_{m,n} \rightarrow 0$  as  $n \rightarrow \infty$ , where  $m = m(n)$  is such that  $m/n \rightarrow 0$  as  $n \rightarrow \infty$ .

The left-hand side of (5.6) can be estimated from above by

$$\begin{aligned} & \left| \sum_{k=0}^{k_\alpha-1} c_k(\alpha) d_{k,n} z^k \right| + \left| \sum_{k=k_\alpha}^m |c_k(\alpha)| d_{k,n} z^k \right| + |c_{n+1}(\alpha)| |z|^{n+1} \left| \sum_{k=0}^{\infty} \left| \frac{c_{k+n+1}(\alpha)}{c_{n+1}(\alpha)} \right| z^k \right| \\ & \quad + |c_{m+1}(\alpha)| |z|^{m+1} \left| \sum_{k=0}^{n-m-1} \left| \frac{c_{k+m+1}(\alpha)}{c_{m+1}(\alpha)} \right| d_{k+m+1,n} z^k \right|, \end{aligned} \quad (6.11)$$

where  $m = m(n)$  is such that  $m \rightarrow \infty$  and  $m/n \rightarrow 0$  as  $n \rightarrow \infty$ . When  $\alpha < 0$  and  $\beta > 0$  the sum (6.11) is bounded by

$$\begin{aligned} & |d_{k_\alpha-1,n}| \max_{0 \leq k < k_\alpha} |c_k(\alpha)| \\ & \quad + 4|1 - z|^{-1} (|c_{k_\alpha}(\alpha)| d_{m,n} + |c_{m+1}(\alpha)| d_{n,n} |z|^{m+1} + |c_{n+1}(\alpha)| |z|^{n+1}) \end{aligned} \quad (6.12)$$

according to Lemma 6.2 from which (5.6) clearly follows. When  $\alpha < 0$  and  $\beta < 0$ , the bound in (6.12) still holds with the only difference being that  $d_{n,n}$  is no longer bounded by 1 but

rather grows like  $n^{-\beta}$ . Hence, if  $m$  is chosen so that  $m/\log n \rightarrow \infty$  as  $n \rightarrow \infty$ , the term  $d_{n,n}|z|^{m+1}$  converges to zero locally uniformly in  $\mathbb{D}$ . When  $\alpha > 0$ , the bound in (6.12) is replaced by

$$4|1-z|^{-1} (c_m(\alpha)d_{m,n} + c_n(\alpha)d_{n,n}|z|^{m+1} + c_{n+1}(\alpha)|z|^{n+1}),$$

again, due to Lemma 6.2. Since  $c_n(\alpha)$  grows like  $n^\alpha$  and  $d_{n,n}$  grows no faster than  $n^{|\beta|}$ , the second and the third terms in the parenthesis converge to zero locally uniformly in  $\mathbb{D}$ . If, in addition, we require that  $m^{1+\alpha}/n \rightarrow 0$  as  $n \rightarrow \infty$ , the first term converges to zero.

Finally, (5.7) follows immediately from (5.3) and (5.6).  $\square$

*Proof of Proposition 5.6.* It holds that

$$M_{\alpha,\beta}(z) = \int_C \frac{B_{\alpha,\beta}(t)}{B(1+\alpha, 1+\beta)} e^{tz} dt \quad (6.13)$$

by (6.1) and the definition of  $B_{\alpha,\beta}$ , see Proposition 5.1. Hence, using the notation from (6.1) and (6.8), we get that (5.9) follows from (5.5) and the computation

$$\begin{aligned} P_n^{\alpha,\beta} \left(1 + \frac{z}{n}\right) &= c_n(\gamma) \int_C \frac{B_{\alpha,\beta}(t)}{B(1+\alpha, 1+\beta)} \left(1 + \frac{zt}{n}\right)^n dt \\ &= (1 + o_n(1))c_n(\gamma) \int_C \frac{B_{\alpha,\beta}(t)}{B(1+\alpha, 1+\beta)} e^{zt} dt. \end{aligned} \quad \square$$

## 6.4 Proof of Theorem 5.7

*Proof of Theorem 5.7.* Set for brevity  $K_N = K_N^{\alpha_1, \beta_1, \alpha_2, \beta_2}$ . It follows from (6.10) that

$$K_N(0, 0) = \sum_{n=0}^{N-1} c_n(\beta_1)c_n(\beta_2) = B^{-1}(\beta_1, \beta_2) \sum_{n=0}^{N-1} (1 + O(1/n))c_n(\beta_1 + \beta_2).$$

Hence, the sequence  $\{K_N(0, 0)\}_N$  is divergent when  $\beta_1 + \beta_2 + 1 \geq 0$  by (6.9). If  $\beta_1 + \beta_2 + 1 < 0$ , this sequence is eventually increasing or decreasing, depending on the sign of  $\Gamma(1 + \beta_1)\Gamma(1 + \beta_2)$ , and converges to

$$\sum_{n=0}^{\infty} c_n(\beta_1)c_n(\beta_2) = {}_2F_1(1 + \beta_1, 1 + \beta_2; 1; 1) = \frac{\Gamma(-1 - \beta_1 - \beta_2)}{\Gamma(-\beta_1)\Gamma(-\beta_2)}, \quad (6.14)$$

where the second equality follows from [13, Eq. 15.4.20]. This proves (5.13).

In order to establish (5.14), we first deduce from (5.6) that

$$\begin{aligned} K_N(z, w) &= \sum_{n=0}^{N-1} c_n(\beta_1)c_n(\beta_2) \left( \frac{1}{(1-z)^{1+\alpha_1}} - o_n(1) \right) \left( \frac{1}{(1-w)^{1+\alpha_2}} - o_n(1) \right) \\ &= \frac{K_N(0, 0)}{(1-z)^{1+\alpha_1}(1-w)^{1+\alpha_2}} + \sum_{n=0}^{N-1} o_n(1)c_n(\beta_1)c_n(\beta_2), \end{aligned}$$

where the functions  $o_n(1)$  hold locally uniformly in either in  $\mathbb{D}$  or  $\mathbb{D} \times \mathbb{D}$ . If  $\beta_1 + \beta_2 + 1 \geq 0$ , the sequence  $\{K_N(0, 0)\}$  diverges to either  $\infty$  or  $-\infty$  and therefore

$$\sum_{n=0}^{N-1} o_n(1)c_n(\beta_1)c_n(\beta_2) = o_N(1)K_N(0, 0),$$

which shows the validity of (5.14). If  $\beta_1 + \beta_2 + 1 < 0$ , the limit  $\lim_{N \rightarrow \infty} K_N(0, 0)$  is finite and therefore

$$\left| \sum_{n=0}^{N-1} o_n(1) c_n(\beta_1) c_n(\beta_2) \right| \ll 1$$

locally uniformly in  $\mathbb{D} \times \mathbb{D}$ . That is, the family  $\{K_N(z, w)\}_N$  is normal. In this case it is sufficient to examine the behavior of the Fourier coefficients of  $K_N(z, w)$ . It holds that

$$K_N(z, w) = \sum_{j,k=0}^{N-1} c_j(\alpha_1) c_k(\alpha_2) \left[ \sum_{n=\max\{j,k\}}^{N-1} c_{n-j}(\beta_1) c_{n-k}(\beta_2) \right] z^j w^k.$$

Using [13, Eq. 15.4.20] as in (6.14), one can compute that the limit of the term in square brackets is equal to

$$\frac{\Gamma(-\beta_1 - \beta_2 - 1)}{\Gamma(1 + \beta_1) \Gamma(1 + \beta_2)} \begin{cases} \frac{\Gamma(1 + \beta_1) \Gamma(1 + \beta_2 + j - k)}{\Gamma(-\beta_2) \Gamma(j - k - \beta_1)}, & j - k \geq 0, \\ \frac{\Gamma(1 + \beta_1 + k - j) \Gamma(1 + \beta_2)}{\Gamma(k - j - \beta_2) \Gamma(-\beta_1)}, & j - k < 0, \end{cases}$$

which is exactly the  $(j - k)$ -th Fourier coefficient of  $\Lambda_{\beta_1, \beta_2}$ , see (5.12). As  $\Lambda_{\beta_1, \beta_2}$  is integrable on  $\mathbb{T}$ , we get from Fubini-Tonelli's theorem that

$$\begin{aligned} \sum_{j,k \geq 0} c_j(\alpha_1) c_k(\alpha_2) \Lambda_{j-k} z^j w^k &= \sum_{j,k \geq 0} c_j(\alpha_1) c_k(\alpha_2) z^j w^k \frac{1}{2\pi} \int_{\mathbb{T}} \bar{\zeta}^{j-k} \Lambda(\zeta) |d\zeta| \\ &= \frac{1}{2\pi} \int_{\mathbb{T}} \frac{\Lambda_{\beta_1, \beta_2}(\zeta)}{(1 - z\bar{\zeta})^{1+\alpha_1} (1 - w\zeta)^{1+\alpha_2}} |d\zeta| \end{aligned}$$

which finishes the proof of (5.15).

To prove (5.16), write

$$\begin{aligned} \frac{K_N(z, w)}{(zw)^N} &= \frac{1}{zw} \sum_{n=0}^{N-1} \frac{c_n(\alpha_1) c_n(\alpha_2)}{(zw)^{N-1-n}} \left( \frac{1}{(1 - 1/z)^{1+\beta_1}} - o_n(1) \right) \left( \frac{1}{(1 - 1/w)^{1+\beta_2}} - o_n(1) \right) \\ &= \frac{1}{zw} \frac{1}{(1 - 1/z)^{1+\beta_1}} \frac{1}{(1 - 1/w)^{1+\beta_2}} \sum_{n=0}^{N-1} (1 + o_{N-1-n}(1)) \frac{c_{N-1-n}(\alpha_1) c_{N-1-n}(\alpha_2)}{(zw)^n}, \end{aligned}$$

where we used (5.7) and the estimates  $o_n(1)$  hold uniformly on closed subsets of either  $\mathbb{O}$  or  $\mathbb{O} \times \mathbb{O}$ . Observe that

$$c_{N-1}(\alpha_1) c_{N-1}(\alpha_2) = (1 + O(N^{-1})) \frac{N^{\alpha_1 + \alpha_2}}{\Gamma(1 + \alpha_1) \Gamma(1 + \alpha_2)}$$

as  $N \rightarrow \infty$  by (6.9) and that

$$\left| \frac{c_m(\alpha_1) c_m(\alpha_2)}{c_{N-1}(\alpha_1) c_{N-1}(\alpha_2)} \right| \ll N^{|\alpha_1 + \alpha_2|}, \quad 0 \leq m \leq N - 1.$$

This, in particular, implies that the family  $\left\{ \frac{K_N(z,w)}{(zw)^N N^{\alpha_1 + \alpha_2}} \right\}_N$  is normal in  $\mathbb{O} \times \mathbb{O}$ . As before, this means that we only need to examine the asymptotic behavior of the Fourier coefficients. As

$$\lim_{N \rightarrow \infty} (1 + o_{N-1-n}(1)) \frac{c_{N-1-n}(\alpha_1) c_{N-1-n}(\alpha_2)}{c_{N-1}(\alpha_1) c_{N-1}(\alpha_2)} = 1$$

for each fixed  $n$ , the proof of (5.16) follows.  $\square$

## 6.5 Proofs of Theorems 5.8 & 5.9

For the proof of Theorem 5.8 we shall need the following fact.

**Lemma 6.3.** *For  $\gamma > -1$ , it holds that*

$$\frac{\Gamma(N)}{\Gamma(N+1+\gamma)} \sum_{n=0}^{N-1} \frac{\Gamma(n+1+\gamma)}{\Gamma(n+1)} (1+\eta)^n = \int_0^1 x^\gamma (1+\eta x)^{N-1} dx. \quad (6.15)$$

*Proof.* It can be readily verified by the principle of mathematical induction that

$$\sum_{j=0}^J \frac{\Gamma(j+1+x)}{\Gamma(j+1)} = \frac{1}{1+x} \frac{\Gamma(J+2+x)}{\Gamma(J+1)}, \quad (6.16)$$

which, upon setting  $J = N - k - 1$ ,  $j = n - k$ , and  $x = k + \gamma$ , is the same as

$$\sum_{n=k}^{N-1} \frac{\Gamma(n+1+\gamma)}{\Gamma(n+1-k)} = \frac{1}{k+\gamma+1} \frac{\Gamma(N+1+\gamma)}{\Gamma(N-k)}.$$

Hence, it holds that

$$\begin{aligned} \sum_{n=0}^{N-1} \frac{\Gamma(n+1+\gamma)}{\Gamma(n+1)} (1+\eta)^n &= \sum_{k=0}^{N-1} \left[ \sum_{n=k}^{N-1} \frac{\Gamma(n+1+\gamma)}{\Gamma(n+1)} \binom{n}{k} \right] \eta^k \\ &= \sum_{k=0}^{N-1} \frac{1}{k+\gamma+1} \frac{\Gamma(N+1+\gamma)}{\Gamma(k+1)\Gamma(N-k)} \eta^k \\ &= \frac{\Gamma(N+1+\gamma)}{\Gamma(N)} \int_0^1 \sum_{k=0}^{N-1} \binom{N-1}{k} x^\gamma (x\eta)^k dx, \end{aligned} \quad (6.17)$$

which finishes the proof of the lemma.  $\square$

Theorem 5.8 is an easy corollary to the following more general claim.

**Lemma 6.4.** *Let  $\alpha_1, \alpha_2 > -1/2$  and  $\{P_n^{\alpha_j}\}_{n \in \mathbb{N}}$  be two sequences of polynomials such that*

$$P_n^{\alpha_j}(z) = [F_j(z) + o_n(1)] \frac{\Gamma(n+1+\alpha_j)}{\Gamma(n+1)} z^n, \quad z \in \overline{\mathbb{O}}, \quad (6.18)$$

*for all  $n \in \mathbb{N}$ , where the functions  $F_j$  are holomorphic in  $\mathbb{O}$ , continuous in  $\overline{\mathbb{O}}$ , and  $o_n(1)$  holds uniformly in  $\overline{\mathbb{O}}$ . Then for any  $\zeta \in \mathbb{T}$  it holds that*

$$K_N^{\alpha_1, \alpha_2}(\zeta, \zeta) = \left[ \frac{F_1(\zeta) \overline{F_2(\zeta)}}{1 + \alpha_1 + \alpha_2} + o_N(1) \right] \frac{\Gamma(N+1+\alpha_1+\alpha_2)}{\Gamma(N)},$$



where  $K_N^{\alpha_1, \alpha_2}(z, w) := \sum_{n=0}^{N-1} P_n^{\alpha_1}(z) \overline{P_n^{\alpha_2}(w)}$ . Moreover, if  $F_1(\zeta)F_2(\zeta) \neq 0$ , then

$$\lim_{N \rightarrow \infty} \frac{K_N^{\alpha_1, \alpha_2}(\zeta + \frac{a_1}{N}, \zeta + \frac{a_2}{N})}{K_N^{\alpha_1, \alpha_2}(\zeta, \zeta)} = E_{\alpha_1 + \alpha_2}(a_1 \bar{\zeta} + \bar{a}_2 \zeta),$$

uniformly for  $a_1, a_2$  on compact subsets of  $\mathbb{C}$ .

*Proof.* Let us first show that the functions  $K_N^{\alpha_1, \alpha_2}(\zeta + \frac{a_1}{N}, \zeta + \frac{a_2}{N}) / K_N^{\alpha_1, \alpha_2}(\zeta, \zeta)$  form a normal family with respect to  $a_1, \bar{a}_2$  whenever the latter belong to a bounded set. To this end, observe that

$$|K_N^{\alpha_1, \alpha_2}(z, w)|^2 \leq |K_N^{\alpha_1}(z, z)| |K_N^{\alpha_2}(w, w)| \quad (6.19)$$

by the Cauchy-Schwartz inequality, where  $K_N^{\alpha_j}(z, w) := \sum_{n=0}^{N-1} P_n^{\alpha_j}(z) \overline{P_n^{\alpha_j}(w)}$ . It follows immediately from their definition that the functions  $K_N^{\alpha_j}(z, z)$  are subharmonic in  $\mathbb{C}$ . Therefore

$$|K_N^{\alpha_j}(z, z)| \leq \max_{\eta \in \mathbb{T}} K_N^{\alpha_j}(\eta, \eta), \quad z \in \mathbb{D},$$

by the maximum principle. Furthermore, as the functions  $K_N^{\alpha_j}(z, z) / |z|^{2N-2}$  are subharmonic in  $\overline{\mathbb{C}} \setminus \mathbb{D}$ , it holds that

$$|K_N^{\alpha_j}(z, z)| \leq |z|^{2N-2} \max_{\eta \in \mathbb{T}} K_N^{\alpha_j}(\eta, \eta), \quad z \in \overline{\mathbb{O}}.$$

Hence, for any constant  $c > 0$  it is true that

$$|K_N^{\alpha_j}(z, z)| \ll_c \max_{\eta \in \mathbb{T}} K_N^{\alpha_j}(\eta, \eta), \quad |z| \leq 1 + \frac{c}{N}. \quad (6.20)$$

Bounds (6.19) and (6.20) are already sufficient for establishing normality, but we still have to show that the claimed normalization constant is proportional to the one coming from (6.19) and (6.20). To accomplish this goal, observe that by (6.10)

$$\frac{\Gamma(n+1+x_1)}{\Gamma(n+1)} \frac{\Gamma(n+1+x_2)}{\Gamma(n+1)} = (1+o_n(1)) \frac{\Gamma(n+1+x_1+x_2)}{\Gamma(n+1)}$$

and therefore

$$K_N^{\alpha_j}(\zeta, \zeta) = \sum_{n=0}^{N-1} |F_j(\zeta) + o_n(1)|^2 \frac{\Gamma(n+1+2\alpha_j)}{\Gamma(n+1)} = \left( \frac{|F_j(\zeta)|^2}{1+2\alpha_j} + o_N(1) \right) \frac{\Gamma(N+1+2\alpha_j)}{\Gamma(N)} \quad (6.21)$$

for  $\zeta \in \mathbb{T}$  by the conditions of the lemma and (6.16). Analogously, it holds that

$$\begin{aligned} K_N^{\alpha_1, \alpha_2}(\zeta, \zeta) &= \sum_{n=0}^{N-1} \left[ F_1(\zeta) \overline{F_2(\zeta)} + o_n(1) \right] \frac{\Gamma(n+1+\alpha_1+\alpha_2)}{\Gamma(n+1)} \\ &= \left[ \frac{F_1(\zeta) \overline{F_2(\zeta)}}{1+\alpha_1+\alpha_2} + o_N(1) \right] \frac{\Gamma(N+1+\alpha_1+\alpha_2)}{\Gamma(N)} \end{aligned} \quad (6.22)$$

for  $\zeta \in \mathbb{T}$ . Formulas (6.21) and (6.22) show that  $|K_N^{\alpha_1, \alpha_2}(\zeta, \zeta)|^2$  and  $|K_N^{\alpha_1}(\zeta, \zeta) K_N^{\alpha_2}(\zeta, \zeta)|$  are of the same order of magnitude when  $F_1(\zeta)F_2(\zeta) \neq 0$ , since as  $N \rightarrow \infty$ ,

$$\frac{\Gamma(N+1+\alpha_1+\alpha_2)^2}{\Gamma(N+1+2\alpha_1)\Gamma(N+1+2\alpha_2)} = 1 + o_N(1) \quad (6.23)$$

Combining (6.19) and (6.20) with the last observation, we deduce that

$$|K_N^{\alpha_1, \alpha_2}(\zeta, \zeta)|^{-1} \left| K_N^{\alpha_1, \alpha_2} \left( \zeta + \frac{a_1}{N}, \zeta + \frac{a_2}{N} \right) \right| \ll_c 1$$

for all  $|a_1|, |a_2| < c$  whenever  $F_1(\zeta)F_2(\zeta) \neq 0$  as claimed.

Given normality, it is enough to establish convergence in some subregion of  $|a_1|, |a_2| < c$ . Hence, in what follows we can assume that  $\zeta + \frac{a_j}{N} \in \mathbb{O}$  for all  $N$  large. Then we deduce from the asymptotic formulae for  $P_n^{\alpha_j}$  that  $K_N^{\alpha_1, \alpha_2}(\zeta + \frac{a_1}{N}, \zeta + \frac{a_2}{N})$  is equal to

$$\sum_{n=0}^{N-1} \left[ F_1(\zeta) \overline{F_2(\zeta)} + o_n(1) \right] \frac{\Gamma(n+1+\alpha_1+\alpha_2)}{\Gamma(n+1)} \left( 1 + \frac{a_1 \bar{\zeta} + \bar{a}_2 \zeta}{N} + \frac{a_1 \bar{a}_2}{N^2} \right)^n$$

and therefore to

$$\left[ F_1(\zeta) \overline{F_2(\zeta)} + o_N(1) \right] \sum_{n=0}^{N-1} \frac{\Gamma(n+1+\alpha_1+\alpha_2)}{\Gamma(n+1)} \left( 1 + \frac{a_1 \bar{\zeta} + \bar{a}_2 \zeta}{N} + \frac{a_1 \bar{a}_2}{N^2} \right)^n \quad (6.24)$$

since  $1 + \alpha_1 + \alpha_2 > 0$ . The latter expression can be rewritten as

$$\left[ F_1(\zeta) \overline{F_2(\zeta)} + o_N(1) \right] \frac{\Gamma(N+1+\alpha_1+\alpha_2)}{\Gamma(N)} \int_0^1 x^{\alpha_1+\alpha_2} \left( 1 + x \left[ \frac{a_1 \bar{\zeta} + \bar{a}_2 \zeta}{N} + \frac{a_1 \bar{a}_2}{N^2} \right] \right)^{N-1} dx$$

by Lemma 6.15. Since

$$\int_0^1 x^{\alpha_1+\alpha_2} \left( 1 + x \left[ \frac{a_1 \bar{\zeta} + \bar{a}_2 \zeta}{N} + \frac{a_1 \bar{a}_2}{N^2} \right] \right)^{N-1} dx = \frac{1 + o_N(1)}{1 + \alpha_1 + \alpha_2} E_{\alpha_1+\alpha_2}(a_1 \bar{\zeta} + \bar{a}_2 \zeta),$$

the lemma follows.  $\square$

For the proof of the main results, we shall need the following lemma.

**Lemma 6.5.** *In the setting of Lemma 6.4, it holds that*

$$\lim_{N \rightarrow \infty} \frac{1}{N^{1+\alpha_2+\alpha_2}} K_N^{\alpha_1, \alpha_2} \left( \zeta + \frac{a_1}{N}, \bar{\zeta} + \frac{\bar{a}_2}{N} \right) = 0, \quad \zeta \in \mathbb{T} \setminus \{\pm 1\},$$

uniformly for  $a_1, a_2$  on compact subsets of  $\mathbb{C}$ .

*Proof.* As in the previous lemma, we get from (6.19), (6.20), (6.21), and (6.23) that the family  $\{N^{-1-\alpha_1-\alpha_2} K_N^{\alpha_1, \alpha_2}(\zeta + \frac{a_1}{N}, \bar{\zeta} + \frac{\bar{a}_2}{N})\}$  is normal with respect to  $a_1, a_2$  on compact subsets of  $\mathbb{C}$ . Hence, we can assume that  $\zeta + \frac{a_j}{N} \in \mathbb{O}$  for all  $N$  large,  $|a_1|, |a_2| < c$ . In the present case, (6.24) is replaced by

$$\left[ F_1(\zeta) F_2(\zeta) + o_N(1) \right] \sum_{n=0}^{N-1} \frac{\Gamma(n+1+\alpha_1+\alpha_2)}{\Gamma(n+1)} \left( \zeta^2 + \frac{a_1+a_2}{N} \zeta + \frac{a_1 a_2}{N^2} \right)^n.$$

Then exactly as in Lemma 6.2 we get that

$$\begin{aligned} & \left| \sum_{n=0}^{N-1} \frac{\Gamma(n+1+\alpha_1+\alpha_2)}{\Gamma(n+1)} \left( \zeta^2 + \frac{a_1+a_2}{N} \zeta + \frac{a_1 a_2}{N^2} \right)^n \right| \\ & \leq \frac{4}{|1 - \zeta^2 - \frac{a_1+a_2}{N} \zeta - \frac{a_1 a_2}{N^2}|} \frac{\Gamma(N+\alpha_1+\alpha_2)}{\Gamma(N)} \end{aligned}$$

As the numbers  $|1 - \zeta^2 - \frac{a_1+a_2}{N} \zeta - \frac{a_1 a_2}{N^2}|$  are bounded away from 0, the claim follows.  $\square$

*Proof of Theorem 5.8.* Since  $P_n^{\beta, \alpha}(0) = c_n(\alpha)$ , see (6.8), it follows from (5.7) that

$$(z-1)P_n^{\alpha_j, \beta_j}(z) = [(1-1/z)^{-\beta_j} + o_n(1)]c_n(\alpha_j)z^{n+1}$$

uniformly in  $\overline{\mathbb{O}}$ . Hence, the theorem is deduced from Lemma 6.4 as

$$(z-1)(w-1)K_N^{\alpha_1, \beta_1, \alpha_2, \beta_2}(z, w) = K_{N+1}^{\alpha_1, \alpha_2}(z, \bar{w}) - 1$$

where we set  $P_0^{\alpha_j}(z) \equiv 1$  and  $P_{n+1}^{\alpha_j}(z) := (z-1)P_n^{\alpha_j, \beta_j}(z)$  for  $n \geq 1$ .  $\square$

*Proof of Theorem 5.9.* Set, for brevity,  $\gamma_j := 1 + \alpha_j + \beta_j$ . It follows from (5.9), (6.10), and (6.16) that, since  $\gamma > -1$ ,

$$\begin{aligned} K_N^{\alpha_1, \beta_1, \alpha_2, \beta_2}(1, 1) &= \sum_{n=0}^{N-1} \frac{1 + o_n(1)}{\Gamma(1 + \gamma_1)\Gamma(1 + \gamma_2)} \frac{\Gamma(n+1 + \gamma)}{\Gamma(n+1)} \\ &= \frac{1 + o_N(1)}{\Gamma(1 + \gamma_1)\Gamma(1 + \gamma_2)} \frac{1}{1 + \gamma} \frac{\Gamma(N+1 + \gamma)}{\Gamma(N)}. \end{aligned}$$

Using (5.5), we get that  $K_N^{\alpha_1, \beta_1, \alpha_2, \beta_2}(1 + \frac{a_1}{N}, 1 + \frac{a_2}{N})$  is equal to

$$\int_C \int_C \frac{B_{\alpha_1, \beta_1}(t)B_{\alpha_2, \beta_2}(u)}{\Gamma(1 + \alpha_1)\Gamma(1 + \beta_1)\Gamma(1 + \alpha_2)\Gamma(1 + \beta_2)} \sum_{n=0}^{N-1} \frac{\Gamma(n+1 + \gamma_1)}{\Gamma(n+1)} \frac{\Gamma(n+1 + \gamma_2)}{\Gamma(n+1)} v_N^n dt du,$$

where  $v_N := 1 + \frac{a_1 t + a_2 u}{N} + \frac{a_1 a_2 t u}{N^2}$ . As in the proof of Lemma 6.4, it holds that

$$\sum_{n=0}^{N-1} \frac{\Gamma(n+1 + \gamma_1)}{\Gamma(n+1)} \frac{\Gamma(n+1 + \gamma_2)}{\Gamma(n+1)} v_N^n = \frac{1 + o_N(1)}{1 + \gamma} \frac{\Gamma(N+1 + \gamma)}{\Gamma(N)} E_\gamma(a_1 t + a_2 u),$$

from which we deduce that the left-hand side of (5.19) is equal to

$$\int_C \int_C \frac{B_{\alpha_1, \beta_1}(t)}{B(1 + \alpha_1, 1 + \beta_1)} \frac{B_{\alpha_2, \beta_2}(u)}{B(1 + \alpha_2, 1 + \beta_2)} E_\gamma(a_1 t + a_2 u) dt du$$

uniformly for  $a, b$  on compact sets. By the very definition of  $E_\gamma$ , we have that

$$\begin{aligned} \int_C \frac{B_{\alpha_1, \beta_1}(t)}{B(1 + \alpha_1, 1 + \beta_1)} E_\gamma(a_1 t + a_2 u) dt &= \int_C \frac{B_{\alpha_1, \beta_1}(t)}{B(1 + \alpha_1, 1 + \beta_1)} (\gamma + 1) \int_0^1 x^\gamma e^{(a_1 t + a_2 u)x} dx dt \\ &= (\gamma + 1) \int_0^1 x^\gamma e^{a_2 u x} \int_C \frac{B_{\alpha_1, \beta_1}(t)}{B(1 + \alpha_1, 1 + \beta_1)} e^{a_1 x t} dt dx \\ &= (\gamma + 1) \int_0^1 x^\gamma e^{a_1 u x} M_{\alpha_1, \beta_1}(a_2 x) dx, \end{aligned}$$

where the last equality follows from (6.13). Thus, the left-hand side of (5.19) is equal to

$$\begin{aligned} (\gamma + 1) \int_0^1 x^\gamma M_{\alpha_1, \beta_1}(a_1 x) \int_C \frac{B_{\alpha_2, \beta_2}(u)}{B(1 + \alpha_2, 1 + \beta_2)} e^{a_2 u x} du dx \\ = (\gamma + 1) \int_0^1 x^\gamma M_{\alpha_1, \beta_1}(a_1 x) M_{\alpha_2, \beta_2}(a_2 x) dx, \end{aligned}$$

which finishes the proof of the theorem.  $\square$

## 6.6 Proofs of Theorems 2.2—2.5

We shall need the following lemma for the proof of Theorem 2.2.

**Lemma 6.6.** *Let  $\zeta \in \mathbb{T} \setminus \{1\}$ ,  $\alpha > 0$  and  $\beta < 0$ . Then for any  $\varepsilon > 0$  it holds that*

$$\lim_{J \rightarrow \infty} J^{-\varepsilon - \alpha} \sum_{j=0}^{J-1} \frac{s_{2j}}{s_{2J}} P_j^{\alpha, \beta} \left( \zeta + \frac{z}{J} \right) = 0$$

locally uniformly in  $\mathbb{C}$ .

*Proof.* Assume first that  $\zeta + z/J \in \overline{\mathbb{D}}$ . As  $P_j^{\beta, \alpha}(0) = c_j(\alpha)$  in the notation (6.8), we get from (5.7) that

$$\sum_{j=0}^{J-1} \frac{s_{2j}}{s_{2J}} P_j^{\alpha, \beta} \left( \zeta + \frac{z}{J} \right) = \sum_{j=0}^{J-1} \left[ (1 - \bar{\zeta})^{-1-\beta} + o_j(1) \right] \frac{s_{2j}}{s_{2J}} c_j(\alpha) \left( \zeta + \frac{z}{J} \right)^j.$$

Since  $\alpha > 0$ ,  $c_j(\alpha) \rightarrow \infty$  and the numbers  $s_{2j}/s_{2J}$  are increasing with  $j$ , it holds that

$$\sum_{j=0}^{J-1} \frac{s_{2j}}{s_{2J}} P_j^{\alpha, \beta} \left( \zeta + \frac{z}{J} \right) = \left[ (1 - \bar{\zeta})^{-1-\beta} + o_J(1) \right] \sum_{j=0}^{J-1} \frac{s_{2j}}{s_{2J}} c_j(\alpha) \left( \zeta + \frac{z}{J} \right)^j.$$

Furthermore, we deduce from Lemma 6.2 that

$$\left| \sum_{j=0}^{J-1} \frac{s_{2j}}{s_{2J}} c_j(\alpha) \left( \eta + \frac{z}{J} \right)^n \right| \leq \frac{4c_{J-1}(\alpha)}{|1 - \zeta - \frac{z}{J}|}. \quad (6.25)$$

Finally, the bound in (6.25) can be extended to all  $\zeta + z/J$  by the maximum modulus principle and the normal family argument. The claim now follows from (6.9).  $\square$

*Proof of Theorem 2.2. Case  $N = 2J$ :* Using relations (4.4), (4.5) and definitions (5.1), (5.10), we get that

$$\begin{aligned} & \max \{1, |z|\}^s \max \{1, |w|\}^s \mathbf{K}_{2J}^{(1,1)}(z, w) \\ &= \frac{1}{2} \left( 1 + \frac{1}{s} \right) \left( wK_J^{(1)}(z^2, w^2) - zK_J^{(1)}(w^2, z^2) \right) \\ & \quad - \frac{3}{2s} \left( wK_J^{(2)}(z^2, w^2) - zK_J^{(2)}(w^2, z^2) \right) \end{aligned} \quad (6.26)$$

where

$$K_J^{(i)}(z, w) := K_J^{1/2, -1/2, i-1/2, -3/2}(z, w), \quad i \in \{1, 2\}. \quad (6.27)$$

Given (1.22), we only need to compute the scaling limit of (6.26).

For brevity, set

$$z_{\zeta, N} := \zeta + \frac{z}{N}, \quad z_{\zeta, N}^2 := \zeta^2 + \frac{z\bar{\zeta}}{J} \left( 1 + \frac{z\bar{\zeta}}{4J} \right). \quad (6.28)$$

Then we deduce from Lemma 6.5 that

$$\lim_{J \rightarrow \infty} J^{-1-i} K_J^{(i)}(z_{\zeta, N}^2, w_{\zeta, N}^2) = 0$$

uniformly on compact subsets of  $\mathbb{C} \times \mathbb{C}$  (as in the proof of Theorem 5.8, we need to multiply  $K_J^{(i)}$  by  $(1 - z_{\zeta, N}^2)(1 - w_{\zeta, N}^2)$  in order to apply Lemma 6.5, but clearly this does not change the limit). Hence,

$$\lim_{J \rightarrow \infty} N^{-2} \mathbf{K}_{2J}^{(1,1)}(z_{\zeta, N}, w_{\zeta, N}) = \lim_{N \rightarrow \infty} N^{-2} \mathbf{K}_{2J}^{(2,2)}(z_{\zeta, N}, w_{\zeta, N}) = 0$$

uniformly on compact subsets of  $\mathbb{C} \times \mathbb{C}$ , where the limit for  $\mathbf{K}_N^{(2,2)}$  follows from the relation

$$\mathbf{K}_{2J}^{(2,2)}(z_{\zeta, N}, w_{\zeta, N}) = \iota(z_{\zeta, N}) \iota(w_{\zeta, N}) \mathbf{K}_{2J}^{(1,1)}(\bar{z}_{\zeta, N}, \bar{w}_{\zeta, N}), \quad (6.29)$$

see (4.5) and (2.2).

On the other hand, we have that

$$\mathbf{K}_{2J}^{(1,2)}(z_{\zeta, N}, w_{\zeta, N}) = \iota(w_{\zeta, N}) \mathbf{K}_{2J}^{(1,1)}(z_{\zeta, N}, \bar{w}_{\zeta, N}). \quad (6.30)$$

Thus, we deduce from Theorem 5.8 that

$$\lim_{J \rightarrow \infty} N^{-1-i} K_J^{(i)}(z_{\zeta, N}^2, \bar{w}_{\zeta, N}^2) = \frac{1}{3^{i-1}(1+i)\pi} \frac{(1-\zeta^2)^{1/2}}{(1-\bar{\zeta}^2)^{1/2}} E_i(z\bar{\zeta} + \bar{w}\zeta)$$

uniformly on compact subsets of  $\mathbb{C} \times \mathbb{C}$ . Recall that the function  $(1-z)^{1/2}$  was defined as holomorphic in the unit disk with the branch cut along the positive reals greater than 1. Thus,  $\text{Arg}((1-e^{it})^{1/2}) = (t-\pi)/4$ ,  $t \in [0, 2\pi]$ . Hence,

$$\bar{z}(1-z^2)^{1/2}(1-\bar{z}^2)^{-1/2} = -\iota(z)$$

and therefore

$$\lim_{J \rightarrow \infty} N^{-2} \mathbf{K}_{2J}^{(1,2)}(z_{\zeta, N}, \bar{w}_{\zeta, N}) = \omega(z\bar{\zeta}) \omega(w\bar{\zeta}) \left[ \frac{1}{2\pi} E_1(z\bar{\zeta} + \bar{w}\zeta) - \frac{\lambda}{3\pi} E_2(z\bar{\zeta} + \bar{w}\zeta) \right]$$

uniformly on compact subsets of  $\mathbb{C} \times \mathbb{C}$ , from which the claim of the theorem follows by the very definition of  $E_i$ , see (5.17).

**Case  $N = 2J + 1$ :** Given (4.6), we only need to show that

$$\lim_{J \rightarrow \infty} N^{-2} \pi_{2J}(z_{\zeta, N}) \sum_{j=0}^{J-1} \frac{s_{2j}}{s_{2J}} \pi_{2j+1}(w_{\eta, N}) = 0$$

uniformly on compact subsets of  $\mathbb{C}$ , where  $\eta = \zeta$  or  $\eta = \bar{\zeta}$ . By (4.4), we wish to take the limit of

$$\frac{1}{4J^2} P_J^{1/2, -1/2}(z_{\zeta, N}^2) \sum_{j=0}^{J-1} \frac{s_{2j}}{s_{2J}} \frac{w_{\eta, N}}{4} \left[ \left(1 + \frac{1}{s}\right) P_j^{1/2, -3/2}(w_{\eta, N}^2) - \frac{3}{s} P_j^{3/2, -3/2}(w_{\eta, N}^2) \right], \quad (6.31)$$

and the claim now follows from Corollary 5.5 and Lemma 6.6.  $\square$

For the proof of Theorem 2.3 we shall need the following two lemmas.

**Lemma 6.7.** *If  $\gamma = 1 + \alpha + \beta > -1$ , it holds that*

$$\lim_{J \rightarrow \infty} \frac{\Gamma(1 + \gamma)}{J^{1 + \gamma}} \sum_{j=0}^{J-1} \frac{s_{2j}}{s_{2J}} P_j^{\alpha, \beta} \left(1 + \frac{z}{J}\right) = \sqrt{1 - \lambda} \int_0^1 \frac{x^\gamma M_{\alpha, \beta}(zx)}{\sqrt{1 - \lambda x}} dx \quad (6.32)$$

locally uniformly in  $\mathbb{C}$ .

*Proof.* When  $\lambda < 1$ , it is a straightforward computation using the asymptotic behavior of the Gamma function to verify

$$\frac{s_{2j}}{s_{2J}} = \frac{\Gamma\left(\frac{s-2j-1}{2}\right)}{\Gamma\left(\frac{s-2j}{2}\right)} \frac{\Gamma\left(\frac{s-2J}{2}\right)}{\Gamma\left(\frac{s-2J-1}{2}\right)} = (1 + o_J(1)) \sqrt{\frac{s-2J}{s-2j}} = (1 + o_J(1)) \sqrt{\frac{1-\lambda}{1-jJ^{-1}}},$$

where we used Lemma 4.4. Then it follows from Proposition 5.6 that

$$\frac{\Gamma(1 + \gamma)}{J^{1 + \gamma}} \sum_{j=0}^{J-1} \frac{s_{2j}}{s_{2J}} P_j^{\alpha, \beta} \left(1 + \frac{z}{J}\right) = \sum_{j=0}^{J-1} \frac{1 + o_j(1)}{J} \left(\frac{j+1}{J}\right)^\gamma \sqrt{\frac{1-\lambda}{1-jJ^{-1}}} M_{\alpha, \beta} \left(\frac{jz}{J}\right).$$

As the right-hand side of the equation above is essentially a Riemann sum for the right-hand side of (6.32), the claim follows.

When  $\lambda = 1$ , it holds that  $s_{2j}/s_{2J} = o_J(1)$ . Hence, replacing the square root by  $o_J(1)$  in the last equation, we see that the left hand side of (6.32) converges to zero.  $\square$

**Lemma 6.8.** *When  $\lambda < 1$ , it holds that*

$$M_{1/2, -1/2}(z) = \frac{1}{\sqrt{1 - \lambda}} \int_0^1 \frac{M(xz) - \lambda x M'(xz)}{\sqrt{1 - \lambda x}} dx.$$

*Proof.* Using the series representation for  $M = M_{1/2, -3/2}$ , see (5.8), and  $M'$  we get that

$$\begin{aligned} & \int_0^1 \frac{M(xz) - \lambda x M'(xz)}{\sqrt{1 - \lambda x}} dx \\ &= \frac{1}{\Gamma(3/2)} \sum_{n=0}^{\infty} \frac{\Gamma(n + 3/2)}{\Gamma(n + 1)} \frac{z^n}{n!} \int_0^1 \left(x^n - \lambda \frac{n + 3/2}{n + 1} x^{n+1}\right) \frac{dx}{\sqrt{1 - \lambda x}}. \end{aligned}$$

Integration by parts yields that

$$\int_0^1 \frac{\lambda x^{n+1}}{\sqrt{1 - \lambda x}} dx = -2\sqrt{1 - \lambda} + 2(n + 1) \int_0^1 \frac{\lambda x^n}{\sqrt{1 - \lambda x}} dx - 2(n + 1) \int_0^1 \frac{\lambda x^{n+1}}{\sqrt{1 - \lambda x}} dx$$

and therefore

$$\int_0^1 \frac{M(xz) - \lambda x M'(xz)}{\sqrt{1 - \lambda x}} dx = \frac{\sqrt{1 - \lambda}}{\Gamma(3/2)} \sum_{n=0}^{\infty} \frac{\Gamma(n + 3/2)}{\Gamma(n + 1)} \frac{z^n}{n!} \frac{1}{n + 1} = \sqrt{1 - \lambda} M_{1/2, -1/2}(z)$$

by (5.8).  $\square$

*Proof of Theorem 2.3. Case  $N = 2J$ :* Let  $z_{\xi,N}$  and  $w_{\xi,N}$  be defined by (6.28). As  $\xi^2 = 1$ , it follows from Theorem 5.9 that

$$\lim_{J \rightarrow \infty} N^{-1-i} K_J^{(i)}(z_{\xi,N}^2, w_{\xi,N}^2) = \frac{1}{1+i} \frac{1}{2^{1+i}} E_{1/2, -1/2, i-1/2, -3/2}(z\xi, w\xi)$$

uniformly on compact subsets of  $\mathbb{C} \times \mathbb{C}$ , where  $K_J^{(i)}$  were defined in (6.27). Hence, we deduce from (6.26) that

$$\begin{aligned} \lim_{J \rightarrow \infty} N^{-2} \mathbf{K}_{2J}^{(1,1)}(z_{\xi,N}, w_{\xi,N}) &= \omega(z\xi) \omega(w\xi) \\ &\times \frac{\xi}{16} \left[ \left( E^{(1)}(z\xi, w\xi) - E^{(1)}(w\xi, z\xi) \right) - \lambda \left( E^{(2)}(z\xi, w\xi) - E^{(2)}(w\xi, z\xi) \right) \right] \end{aligned}$$

where  $E^{(i)} := E_{1/2, -1/2, i-1/2, -3/2}$ . By the very definition, see (5.18), it holds that

$$\begin{aligned} &E^{(i)}(a_1, a_2) - E^{(i)}(a_2, a_1) \\ &= (1+i) \int_0^1 x^i \left[ M_{1/2, -1/2}(a_1 x) M_{i-1/2, -3/2}(a_2 x) - M_{1/2, -1/2}(a_2 x) M_{i-1/2, -3/2}(a_1 x) \right] dx. \end{aligned} \tag{6.33}$$

The following relations can be readily checked:

$$M(x) = M_{1/2, -3/2}(x), \quad M_{3/2, -3/2}(x) = \frac{2}{3} M'(x); \quad M_{1/2, -1/2}(x) = 2(M'(x) - M(x)). \tag{6.34}$$

Plugging these relations into (6.33), we obtain the desired limit for  $\mathbf{K}_{2J}^{(1,1)}$ .

**Case:  $N = 2J + 1$ :** In this case we need to deal with additional limits of the form (6.31) where  $\zeta = \eta = \xi$ . It follows from Proposition 5.6 and Lemma 6.7 that the limit of (6.31) is equal to

$$\sqrt{1-\lambda} \frac{\xi}{16} M_{1/2, -1/2}(z\xi) \int_0^1 \frac{M_{1/2, -3/2}(xw\xi) - \frac{3}{2} \lambda x M_{3/2, -3/2}(xw\xi)}{\sqrt{1-\lambda x}} dx.$$

Thus, this limit is zero when  $\lambda = 1$  and is equal to

$$\sqrt{1-\lambda} \frac{\xi}{16} M_{1/2, -1/2}(z\xi) \frac{\xi}{16} M_{1/2, -1/2}(w\xi) \tag{6.35}$$

when  $\lambda < 1$  by (6.34) and Lemma 6.8. Since (6.35) is symmetric with respect to  $z$  and  $w$ , the additional terms in (4.6) cancel each other out.  $\square$

*Proof of Lemma 2.6.* Set  $F(b) := \frac{1}{4} |M(z)|^2$ , where  $z = a + ib$ . It follows from [13, Eq. 13.7.2] that  $\lim_{|b| \rightarrow \infty} F(b)/G(b) = 1$ , where  $G(b) := |z|e^{2a}/\pi$ . As both functions tend to infinity as  $|b| \rightarrow \infty$ , L'Hôpital's rule yields that  $\lim_{|b| \rightarrow \infty} F'(b)|z|/b = e^{2a}/\pi$ . Since  $F'(b) = [M'(z)M'(\bar{z}) - M(z)M'(\bar{z})]/4$ , the claim of the lemma follows.  $\square$

For the proof of Theorem 2.5 we shall need the following lemma.

**Lemma 6.9.** *Let  $\xi = \pm 1$ . For  $y \in \mathbb{R}$ , it holds that*

$$\begin{cases} (\epsilon \tilde{\pi}_{2n})(y) &= -\xi - \int_{\xi}^y \tilde{\pi}_{2n}(u) du, \\ (\epsilon \tilde{\pi}_{2n+1})(y) &= \frac{1}{4s} - \int_{\xi}^y \tilde{\pi}_{2n+1}(u) du. \end{cases} \quad (6.36)$$

*Proof.* It is a straightforward calculation to get that

$$\epsilon \left( x^{2k} \max \{1, |x|\}^{-s} \right) (y) = - \int_{\xi}^y x^{2k} \max \{1, |x|\}^{-s} dx - \frac{\xi}{2k+1}.$$

Hence, using the representation from Theorem 4.1, we get that

$$\begin{aligned} (\epsilon \tilde{\pi}_{2n})(y) &= - \int_{\xi}^y \tilde{\pi}_{2n}(x) dx - \frac{\xi}{\pi} \sum_{k=0}^n \frac{\Gamma(k+1/2) \Gamma(n-k+1/2)}{\Gamma(k+1) \Gamma(n-k+1)} \\ &= - \int_{\xi}^y \tilde{\pi}_{2n}(x) dx - \xi P_n^{-1/2, -1/2}(1). \end{aligned}$$

As  $P_n^{-1/2, -1/2}(1) = 1$  by (5.9), the first claim in (6.36) follows. Analogously, it holds that

$$\epsilon \left( x^{2k+1} \max \{1, |x|\}^{-s} \right) (y) = - \int_{\xi}^y x^{2k+1} \max \{1, |x|\}^{-s} dx + \frac{1}{s-2k-2}$$

and therefore

$$\begin{aligned} (\epsilon \tilde{\pi}_{2n+1})(y) &= - \int_{\xi}^y \tilde{\pi}_{2n+1}(u) du - \frac{1}{4\pi s} \sum_{k=0}^n \frac{\Gamma(k+3/2) \Gamma(n-k-1/2)}{\Gamma(k+1) \Gamma(n-k+1)} \\ &= - \int_{\xi}^y \tilde{\pi}_{2n+1}(u) du + \frac{1}{4s} P_n^{1/2, -3/2}(1), \end{aligned}$$

which finishes the proof of (6.36) as  $P_n^{1/2, -3/2}(1) = 1$  by (5.9).  $\square$

For the proof of Theorem 2.5 we shall need the following relation

$$M_{\alpha, \beta+1}(z) = (1 + \gamma) \int_0^1 x^\gamma M_{\alpha, \beta}(zx) dx; \quad \gamma = 1 + \alpha + \beta. \quad (6.37)$$

*Proof of Theorem 2.5.* To prove the theorem we need to show that the scaling limits (1.19) of the matrix kernel (1.12) are equal to (2.4) with  $A = A_\xi$  defined by (2.5). As in the previous two theorems, we use notation and expressions of (4.5) & (4.6) for the entries of  $\mathbf{K}_N$ . Notice also that the fourth case in (2.4) is simply a restatement of Corollary 2.4. As usual we shall use (4.4) & (5.1) throughout the analysis.

**Case  $N = 2J$ :** Recall that  $\mathbf{K}_{2J}^{(1,1)}$  does not contain the  $\epsilon$  operator and therefore remains the same for all cases. Further, we get from Lemma 6.9 that

$$\begin{aligned} \mathbf{K}_{2J}^{(1,2)}(z, y) &= 2 \sum_{j=0}^{J-1} \left[ \tilde{\pi}_{2j}(z) \left( \frac{1}{4s} - \int_{\xi}^y \tilde{\pi}_{2j+1}(x) dx \right) + \tilde{\pi}_{2j+1}(z) \left( \xi + \int_{\xi}^y \tilde{\pi}_{2j}(x) dx \right) \right] \\ &= - \int_{\xi}^y \mathbf{K}_{2J}^{(1,1)}(z, x) dx + \frac{1}{2s} \sum_{j=0}^{J-1} \tilde{\pi}_{2j}(z) + 2\xi \sum_{j=0}^{J-1} \tilde{\pi}_{2j+1}(z). \end{aligned}$$



With the notation (6.28), observe that

$$\lim_{J \rightarrow \infty} \frac{1}{N} \int_{\xi}^{y_{\xi, N}} \mathbf{K}_{2J}^{(1,1)}(z_{\xi, N}, v) dv = \int_0^y \lim_{J \rightarrow \infty} \frac{1}{N^2} \mathbf{K}_{2J}^{(1,1)}(z_{\xi, N}, v_{\xi, N}) dv = \int_0^y \varkappa_{\xi}(z, v) dv \quad (6.38)$$

locally uniformly in  $\mathbb{C} \times \mathbb{R}$  by Theorem 2.3. It also follows from (6.32) applied with  $s = \infty$  (in which case  $s_{2j}/s_{2J} = 1$  and  $\lambda = 0$ ) that

$$\lim_{J \rightarrow \infty} \frac{2}{J^2} \sum_{j=0}^{J-1} P_j^{1/2, -1/2}(z_{\xi, N}^2) = M_{1/2, 1/2}(z\xi) = 4 \int_0^1 u (M'(z\xi u) - M(z\xi u)) du,$$

where we used (6.37) and (6.34). Hence, it holds that

$$\lim_{J \rightarrow \infty} \frac{1}{2sN} \sum_{j=0}^{J-1} \tilde{\pi}_{2j}(z_{\xi, N}) = \frac{\omega(z\xi)}{4} \int_0^1 \lambda u (M'(z\xi u) - M(z\xi u)) du \quad (6.39)$$

locally uniformly in  $\mathbb{C}$ . Once more, we deduce from (6.32) and (6.37) that, for  $i \in \{0, 1\}$ ,

$$\lim_{J \rightarrow \infty} \frac{2^i}{J^{1+i}} \sum_{j=0}^{J-1} P_j^{i+1/2, -3/2}(z_{\xi, N}^2) = M_{i+1/2, -1/2}(z\xi) = (1+i) \int_0^1 u^i M_{i+1/2, -3/2}(z\xi u) du.$$

Thus, we get that

$$\lim_{J \rightarrow \infty} \frac{2\xi}{N} \sum_{j=0}^{J-1} \tilde{\pi}_{2j+1}(z_{\xi, N}) = \frac{\omega(z\xi)}{4} \int_0^1 (M(z\xi u) - \lambda u M'(z\xi u)) du \quad (6.40)$$

locally uniformly in  $\mathbb{C}$ , where we again used (6.34). Combining (6.38)–(6.40), we get that

$$\begin{aligned} \lim_{J \rightarrow \infty} \frac{1}{N} \mathbf{K}_{2J}^{(1,2)}(z_{\xi, N}, y_{\xi, N}) &= - \int_0^y \varkappa_{\xi}(z, v) dv + \frac{\omega(z\xi)}{4} \int_0^1 (1 - \lambda u) M(z\xi u) du \\ &= -DA_{\xi}(z, y). \end{aligned} \quad (6.41)$$

This finishes the proof of the second and the third cases in (2.4) since

$$\begin{cases} \mathbf{K}_{2J}^{(2,1)}(z_{\xi, N}, y_{\xi, N}) &= \iota(z_{\xi, N}) \mathbf{K}_{2J}^{(1,1)}(\bar{z}_{\xi, N}, y_{\xi, N}) \\ \mathbf{K}_{2J}^{(2,2)}(z_{\xi, N}, y_{\xi, N}) &= \iota(z_{\xi, N}) \mathbf{K}_{2J}^{(1,2)}(\bar{z}_{\xi, N}, y_{\xi, N}) \end{cases}.$$

To prove the first equality in (2.4), notice that (6.41) provides us with the terms on the anti-diagonal of  $\mathbf{K}_{2J}(x, y)$ . Thus, we only need to compute the limit of the  $\mathbf{K}_{2J}^{(2,2)}(x_{\xi, N}, y_{\xi, N})$  (observe the presence of  $\frac{1}{2} \operatorname{sgn}(y_{\xi, N} - x_{\xi, N}) = \frac{1}{2} \operatorname{sgn}(y - x)$  in (1.12)). To this end, we get from Lemma 6.9 that

$$\begin{aligned} \mathbf{K}_{2J}^{(2,2)}(x, y) &= 2 \sum_{j=0}^{J-1} \left[ - \left( \xi + \int_{\xi}^x \tilde{\pi}_{2j}(v) dv \right) \left( \frac{1}{4s} - \int_{\xi}^y \tilde{\pi}_{2j+1}(v) dv \right) \right. \\ &\quad \left. + \left( \frac{1}{4s} - \int_{\xi}^x \tilde{\pi}_{2j+1}(v) dv \right) \left( \xi + \int_{\xi}^y \tilde{\pi}_{2j}(v) dv \right) \right] \\ &= \int_{\xi}^x \int_{\xi}^y \mathbf{K}_{2J}^{(1,1)}(u, v) dv du + \left( \int_{\xi}^y - \int_{\xi}^x \right) \sum_{j=0}^{J-1} \left( \frac{1}{2s} \tilde{\pi}_{2j}(v) + 2\xi \tilde{\pi}_{2j+1}(v) \right) dv. \end{aligned}$$

As before, we get that

$$\int_{\xi}^{x_{\xi,N}} \int_{\xi}^{y_{\xi,N}} \mathbf{K}_{2J}^{(1,1)}(u, v) dv du = N^{-2} \int_0^x \int_0^y \mathbf{K}_{2J}^{(1,1)}(u_{\xi,N}, v_{\xi,N}) dv du$$

and therefore this term approaches  $\int_0^x \int_0^y \varkappa_{\xi}(u, v) dv du$  locally uniformly in  $\mathbb{R} \times \mathbb{R}$ . Moreover, we have that

$$\int_{\xi}^{x_{\xi,N}} \sum_{j=0}^{J-1} \left( \frac{1}{2s} \tilde{\pi}_{2j}(v) + 2\xi \tilde{\pi}_{2j+1}(v) \right) dv = N^{-1} \int_0^x \sum_{j=0}^{J-1} \left( \frac{1}{2s} \tilde{\pi}_{2j}(v_{\xi,N}) + 2\xi \tilde{\pi}_{2j+1}(v_{\xi,N}) \right) dv$$

and therefore this term converges to

$$\int_0^x \frac{\omega(v\xi)}{4} \int_0^1 (1 - \lambda u) M(v\xi u) du dv.$$

Since the second integral for this sum can be handled similarly, we see that  $\mathbf{K}_{2J}^{(2,2)}(x_{\xi,N}, y_{\xi,N})$  approaches  $A_{\xi}(x, y)$  as claimed.

**Case  $N = 2J + 1$ :** As in the case of even  $N$ , we only need to consider the scaled limits of  $\mathbf{K}_N^{(1,2)}$  and  $\mathbf{K}_N^{(2,2)}$ . It follows from (4.6) that

$$\mathbf{K}_{2J+1}^{(1,2)}(z, y) - \mathbf{K}_{2J}^{(1,2)}(z, y) = -2 \sum_{j=0}^{J-1} \frac{s_{2j}}{s_{2J}} \left[ \tilde{\pi}_{2J}(z) \epsilon \tilde{\pi}_{2j+1}(y) - \epsilon \tilde{\pi}_{2J}(y) \tilde{\pi}_{2j+1}(z) \right] + \frac{\tilde{\pi}_{2J}(z)}{s_{2J}}$$

which is equal to

$$- \int_{\xi}^y \left( \mathbf{K}_{2J+1}^{(1,1)}(z, v) - \mathbf{K}_{2J}^{(1,1)}(z, v) \right) dv - \sum_{j=0}^{J-1} \frac{s_{2j}}{s_{2J}} \left( \frac{1}{2s} \tilde{\pi}_{2J}(z) + 2\xi \tilde{\pi}_{2j+1}(z) \right) + \frac{\tilde{\pi}_{2J}(z)}{s_{2J}}$$

by Lemma 6.9. We get that

$$\begin{aligned} \frac{1}{N} \int_{\xi}^{y_{\xi,N}} \left( \mathbf{K}_{2J+1}^{(1,1)}(z_{\xi,N}, v) - \mathbf{K}_{2J}^{(1,1)}(z_{\xi,N}, v) \right) dv \\ = \frac{1}{N^2} \int_0^y \left( \mathbf{K}_{2J+1}^{(1,1)}(z_{\xi,N}, v_{\xi,N}) - \mathbf{K}_{2J}^{(1,1)}(z_{\xi,N}, v_{\xi,N}) \right) dv, \end{aligned} \quad (6.42)$$

which converges locally uniformly to zero by Theorem 2.3. Further, we have that

$$\lim_{J \rightarrow \infty} \frac{1}{2sN} \tilde{\pi}_{2J}(z_{\xi,N}) \sum_{j=0}^{J-1} \frac{s_{2j}}{s_{2J}} = \frac{\omega(z\xi)}{4} \frac{\lambda \sqrt{1-\lambda}}{1 + \sqrt{1-\lambda}} M_{1/2, -1/2}(z\xi) \quad (6.43)$$

by (5.9) and (6.32) applied at  $z = 0$  with any pair of parameters such that  $\gamma = 0$ . Moreover, we get from Lemmas 6.7 & 6.8 that

$$\lim_{J \rightarrow \infty} \frac{2\xi}{N} \sum_{j=0}^{J-1} \frac{s_{2j}}{s_{2J}} \tilde{\pi}_{2j+1}(z_{\xi,N}) = \frac{\omega(z\xi)}{4} (1 - \lambda) M_{1/2, -1/2}(z\xi). \quad (6.44)$$

At last, we have that  $\lim_{J \rightarrow \infty} s_{2J}^{-1} = \sqrt{1 - \lambda}/2$ , which, in combination with (5.9), yields that

$$\lim_{J \rightarrow \infty} \frac{1}{s_{2J} N} \tilde{\pi}_{2J}(z_{\xi, N}) = \frac{\omega(z_{\xi})}{4} \sqrt{1 - \lambda} M_{1/2, -1/2}(z_{\xi}). \quad (6.45)$$

Combining the conclusion of (6.42) with (6.43)–(6.45), we get that

$$\lim_{J \rightarrow \infty} N^{-1} \left( \mathbf{K}_{2J+1}^{(1,2)}(z_{\xi, N}, y_{\xi, N}) - \mathbf{K}_{2J}^{(1,2)}(z_{\xi, N}, y_{\xi, N}) \right) = 0 \quad (6.46)$$

locally uniformly in  $\mathbb{C} \times \mathbb{R}$ .

Finally, let us settle the case  $x, y \in \mathbb{R}$ . The only difference from above is in the  $\mathbf{K}_{2J+1}^{(2,2)}$  component. It holds that  $\mathbf{K}_{2J+1}^{(2,2)}(x, y) - \mathbf{K}_{2J}^{(2,2)}(x, y)$  is equal to

$$-2 \sum_{j=0}^{J-1} \frac{s_{2j}}{s_{2J}} \left[ \epsilon \tilde{\pi}_{2J}(x) \epsilon \tilde{\pi}_{2j+1}(y) - \epsilon \tilde{\pi}_{2J}(y) \epsilon \tilde{\pi}_{2j+1}(x) \right] + \frac{\epsilon \tilde{\pi}_{2J}(x) - \epsilon \tilde{\pi}_{2J}(y)}{s_{2J}},$$

which itself is equal to

$$\begin{aligned} & \int_{\xi}^x \int_{\xi}^y \left( \mathbf{K}_{2J+1}^{(1,1)}(u, v) - \mathbf{K}_{2J}^{(1,1)}(u, v) \right) dv du \\ & + \left( \int_{\xi}^y - \int_{\xi}^x \right) \left( - \sum_{j=0}^{J-1} \frac{s_{2j}}{s_{2J}} \left[ \frac{1}{2s} \tilde{\pi}_{2J}(v) + 2\xi \tilde{\pi}_{2j+1}(v) \right] + \frac{\tilde{\pi}_{2J}(v)}{s_{2J}} \right) dv. \end{aligned}$$

The claim of the theorem now follows by appealing to (6.46) and the conclusion of (6.42).  $\square$

## 6.7 Proofs of Theorems 2.7—2.9

For the proof of Theorem 2.7 we shall need the following restatement of Lemma 6.9.

**Lemma 6.10.** *For  $y \in (-1, 1)$ , it holds that*

$$\begin{cases} (\epsilon \tilde{\pi}_{2n})(y) &= - \int_0^y \tilde{\pi}_{2n}(u) du, \\ (\epsilon \tilde{\pi}_{2n+1})(y) &= - \frac{1}{4} P_{n+1}^{-1/2, -3/2}(0) - \int_0^y \tilde{\pi}_{2n+1}(u) du. \end{cases} \quad (6.47)$$

*Proof.* We start with formulae (6.36). Since  $-\int_1^y = -\int_0^y + \int_0^1$ , we just need to compute the latter integral in both cases. It follows from Theorem 4.1 and (5.1) that

$$\int_0^1 \tilde{\pi}_{2n}(u) du = P_n^{-1/2, -1/2}(1) = 1 \quad (6.48)$$

by (5.9). Analogously, we have that

$$\begin{aligned} \int_0^1 \tilde{\pi}_{2n+1}(u) du &= \frac{1}{4} \left( P_n^{-1/2, -3/2}(1) - P_{n+1}^{-1/2, -3/2}(0) - \frac{1}{s} P_n^{1/2, -3/2}(1) \right) \\ &= -\frac{1}{4} P_{n+1}^{-1/2, -3/2}(0) - \frac{1}{4s}, \end{aligned}$$

where  $P_n^{-1/2, -3/2}(1) = 0$  by (5.9). Combining the above equalities with (6.36) yields (6.47).  $\square$

*Proof of Theorem 2.7.* To prove the theorem we need to show that the matrix kernel (1.12) converges to (2.4) with  $A = A_{\mathbb{D}}$  defined by (2.6). As before, we employ (4.5) & (4.6).

**Case  $N = 2J$ :** Recall that formula (6.26) holds for all  $z, w$ . Thus,  $\mathbf{K}_{2J}^{(1,1)}(z, w)$  is equal to the right-hand side of (6.26) when  $z, w \in \mathbb{D}$ . Therefore, we need to analyze the behavior of  $K_j^{(i)}$ , see (6.27), in  $\mathbb{D} \times \mathbb{D}$ . Limit (5.15) yields that

$$\lim_{J \rightarrow \infty} K_J^{(i)}(z^2, w^2) = \frac{1}{2\pi} \int_{\mathbb{T}} \frac{\Lambda_{-1/2, -3/2}(\tau) |d\tau|}{(1 - z^2 \bar{\tau})^{3/2} (1 - w^2 \tau)^{(2i+1)/2}}$$

locally uniformly in  $\mathbb{D} \times \mathbb{D}$ . As  $\Lambda_{-1/2, -3/2}(\tau) = \sqrt{-\tau}$ , one can readily verify that the functions  $\mathbf{K}_{2J}^{(1,1)}(z, w)$  converge to  $DA_{\mathbb{D}}D(z, w)$ . This proves the complex/complex case the theorem.

Let now  $y \in (-1, 1)$ . Then it follows from Lemma 6.10 that

$$\begin{aligned} \mathbf{K}_{2J}^{(1,2)}(z, y) &= - \int_0^y \mathbf{K}_{2J}^{(1,1)}(z, v) dv - \frac{1}{2} \sum_{j=0}^{J-1} \pi_{2j}(z) P_{j+1}^{-1/2, -3/2}(0) \\ &= - \int_0^y \mathbf{K}_{2J}^{(1,1)}(z, v) dv - \frac{1}{2} \left( K_{J+1}^{1/2, -1/2, -1/2, -3/2}(z^2, 0) - K_{J+1}^{1/2, -3/2, -1/2, -3/2}(z^2, 0) \right) \end{aligned}$$

where we used (4.4) and (5.2). The first term in the last sum converges to

$$- \int_0^y DA_{\mathbb{D}}D(z, v) dv = DA_{\mathbb{D}}(z, 0) - DA_{\mathbb{D}}(z, y)$$

and the second term converges to

$$- \frac{1}{4\pi} \int_{\mathbb{T}} \frac{(\Lambda_{-1/2, -3/2}(\tau) - \Lambda_{-3/2, -3/2}(\tau)) |d\tau|}{(1 - z^2 \bar{\tau})^{3/2}} = -DA_{\mathbb{D}}(z, 0),$$

by (5.15) and the computation

$$\Lambda_{-1/2, -3/2}(\tau) - \Lambda_{-3/2, -3/2}(\tau) = -\Lambda_{-3/2, -1/2}(\tau) = -\Lambda_{-1/2, -3/2}(\bar{\tau}).$$

This yields the complex/real case of the theorem.

Let now  $x, y \in (-1, 1)$ . It follows from Lemma 6.10 that

$$\mathbf{K}_{2J}^{(2,2)}(x, y) = \int_0^x \int_0^y \mathbf{K}_{2J}^{(1,1)}(u, v) dv du + \left( \int_0^x - \int_0^y \right) \left( \frac{1}{2} \sum_{j=0}^{J-1} \pi_{2j}(u) P_{j+1}^{-1/2, -3/2}(0) \right) du.$$

Immediately, we get that

$$\lim_{N \rightarrow \infty} \mathbf{K}_{2J}^{(2,2)}(x, y) = \int_0^x \int_0^y DA_{\mathbb{D}}D(u, v) dv du + \left( \int_0^x - \int_0^y \right) DA_{\mathbb{D}}(u, 0) du = A_{\mathbb{D}}(x, y),$$

where for the last equality we used the fact that  $A_{\mathbb{D}}(x, y)$  is anti-symmetric and is zero at  $(0, 0)$ . This finishes the proof of the real/real case.

**Case  $N = 2J + 1$ :** It holds by (5.6) and (4.4) that

$$\begin{cases} \pi_{2J}(z) &= c_J(-1/2) \left( (1-z)^{-3/2} + o_J(1) \right) \\ \pi_{2j+1}(w) &= \frac{w}{4} c_j(-3/2) \left( \left(1 + \frac{1}{s}\right) (1-w)^{-3/2} - \frac{3}{s} (1-w)^{-5/2} + o_j(1) \right) \end{cases}$$

locally uniformly for  $z, w \in \mathbb{D}$ . As the numbers  $s_{2j}/s_{2J}$  are bounded and  $c_J(-1/2) \sim (J+1)^{-1/2}$ ,  $c_j(-3/2) \sim (j+1)^{-3/2}$  by (6.9), we get that

$$\pi_{2J}(z) \sum_{j=0}^{J-1} \frac{s_{2j}}{s_{2J}} \pi_{2j+1}(w) = o_J(1)$$

locally uniformly in  $\mathbb{D} \times \mathbb{D}$ . Therefore,  $\mathbf{K}_{2J+1}^{(1,1)}$  has the same limit as  $\mathbf{K}_{2J}^{(1,1)}$  as  $J \rightarrow \infty$ .

Further, by (6.47), we have that

$$\begin{aligned} \left( \mathbf{K}_{2J+1}^{(1,2)} - \mathbf{K}_{2J}^{(1,2)} \right) (z, y) &= \\ &= - \int_0^y \left( \mathbf{K}_{2J+1}^{(1,1)} - \mathbf{K}_{2J}^{(1,1)} \right) (z, v) dv + \frac{\pi_{2J}(z)}{2} \sum_{j=0}^{J-1} \frac{s_{2j}}{s_{2J}} P_{j+1}^{-1/2, -3/2}(0) + \frac{\pi_{2J}(z)}{s_{2J}}. \end{aligned}$$

As  $P_{j+1}^{-1/2, -3/2}(0) = c_{j+1}(-3/2)$  and  $s_{2J} > 1$ , this difference converges to zero locally uniformly in  $\mathbb{D} \times \mathbb{D}$ .

Finally, observe that the difference  $\left( \mathbf{K}_{2J+1}^{(2,2)} - \mathbf{K}_{2J}^{(2,2)} \right) (x, y)$  is equal to

$$\begin{aligned} & \int_0^x \int_0^y \left( \mathbf{K}_{2J+1}^{(1,1)} - \mathbf{K}_{2J}^{(1,1)} \right) (u, v) dv du \\ & + \left( \int_0^y - \int_0^x \right) \left( \frac{\pi_{2J}(v)}{2} \sum_{j=0}^{J-1} \frac{s_{2j}}{s_{2J}} P_{j+1}^{-1/2, -3/2}(0) + \frac{\pi_{2J}(v)}{s_{2J}} \right) dv, \end{aligned}$$

which converges to zero locally uniformly in  $\mathbb{D} \times \mathbb{D}$ . This finishes the proof of the theorem.  $\square$

The following lemma is needed for the proof of Theorem 2.8.

**Lemma 6.11.** *It holds that*

$$\lim_{J \rightarrow \infty} \frac{\sqrt{J}}{s - 2J - 1} \frac{1}{z^{2J}} \sum_{j=0}^{J-1} \frac{s_{2j}}{s_{2J}} \pi_{2j+1}(z) = \frac{\lambda}{4\sqrt{\pi}} \frac{1}{\sqrt{z^2 - 1}}$$

locally uniformly in  $\mathbb{O}$ .

*Proof.* Using notation (6.8), we get from Theorem 4.1 that

$$\begin{aligned} \pi_{2j+1}(z) &= \frac{z^{2j+1}}{4s} \sum_{k=0}^j (s - 2(k+1)) c_k(1/2) c_{j-k}(-3/2) z^{-(j-k)} \\ &= \frac{z^{2j+1}}{4s} c_j(1/2) \sum_{i=0}^j (s - 2j - 2 + 2i) \frac{c_{j-i}(1/2)}{c_j(1/2)} \frac{c_i(-3/2)}{z^{2i}} \\ &= \frac{z^{2j+1}}{4s} c_j(1/2) \left( (s - 1 - 2j) \sum_{i=0}^j \frac{c_{j-i}(1/2)}{c_j(1/2)} \frac{c_i(-3/2)}{z^{2i}} - \sum_{i=0}^j \frac{c_{j-i}(1/2)}{c_j(1/2)} \frac{c_i(-1/2)}{z^{2i}} \right). \end{aligned}$$

Thus, using the standard normal family argument, we get that

$$\begin{aligned}\pi_{2j+1}(z) &= z^{2j+1} \frac{c_j(1/2)}{4s} \left( (s-1-2j)(f(z) + o_j(1)) - (1/f(z) + o_j(1)) \right) \\ &= \frac{z^{2j+1}}{f(z)} \frac{c_j(1/2)}{4s} \left( (s-2-2j)(1 + o_j(1)) - z^{-2}(s-1-2j) \right)\end{aligned}\quad (6.49)$$

locally uniformly in  $\mathbb{O}$ , where  $f(z) = \sqrt{1-1/z^2}$ . Observe that

$$c_j(1/2) = \left(1 - \frac{1}{2j}\right) c_{j-1}(1/2)$$

and that  $(s-2-2j)s_{2j} = (s-3-2j)s_{2j+2}$  by Lemma 4.4. Therefore,

$$(s_{2j}/s_{2J})\pi_{2j+1}(z) = (1 + o_j(1))B_{j+1}(z) - (1 + o_j(1))B_j(z),$$

where we set

$$B_j(z) := \frac{z^{2j-1}}{f(z)} \frac{c_j(1/2)}{4s} \frac{s_{2j}}{s_{2J}} (s-1-2j).$$

Hence,

$$\sum_{j=0}^{J-1} \frac{s_{2j}}{s_{2J}} \pi_{2j+1}(z) = B_J(z) - B_0(z) + \sum_{j=1}^{J-1} o_{J-j}(1) B_{J-j}(z).$$

For each fixed  $j \geq 0$ , we have that

$$\lim_{J \rightarrow \infty} \frac{\sqrt{J}}{s-2J-1} \frac{B_{J-j}(z)}{z^{2J}} = \frac{1+2jc^{-1}}{z^{2j+1}f(z)} \frac{\lambda}{4\sqrt{\pi}} \lim_{J \rightarrow \infty} \frac{s_{2J-2j}}{s_{2J}},$$

where  $c := \lim_{J \rightarrow \infty} (s-2J-1)$  ( $c^{-1} = 0$  when  $c = \infty$ ). The latter limit exists and is finite by Lemma 4.4 (clearly, equal to 1 when  $j = 0$ ). Moreover,

$$\lim_{J \rightarrow \infty} \frac{\sqrt{J}}{s-2J-1} \frac{B_0(z)}{z^{2J}} = 0$$

locally uniformly in  $\mathbb{O}$ . Thus, the claim of the lemma now follows from the standard normal family argument.  $\square$

*Proof of Theorem 2.8.* We rely heavily on (1.12), (4.5) & (4.6), which will be used without explicit mention.

**Case  $N = 2J$ :** In order to prove (2.7), we shall need to repeat the argument leading to the proof of (5.16). As in the previous lemma, set  $f(z) := \sqrt{1-1/z^2}$ . We get from (6.49) and (5.7) that

$$\begin{aligned}\frac{2}{s-2J} \frac{f(z)f(w)}{(zw)^{2J-1}} \sum_{j=0}^{J-1} [\pi_{2j}(z)\pi_{2j+1}(w) - \pi_{2j}(w)\pi_{2j+1}(z)] &= \\ \sum_{j=0}^{J-1} \frac{c_{J-1-j}^2(1/2)}{2s} \left(1 + \frac{2j}{s-2J}\right) \frac{w(1+o_{J-1-j}(1)) - z(1+o_{J-1-j}(1))}{(zw)^{2j+1}} &+ \\ + \sum_{j=0}^{J-1} \frac{c_{J-1-j}^2(1/2)}{2s} \left(1 + \frac{2j+1}{s-2J}\right) \frac{w(1+o_{J-1-j}(1)) - z(1+o_{J-1-j}(1))}{(zw)^{2j+2}}.\end{aligned}\quad (6.50)$$

Since  $\lim_{J \rightarrow \infty} (s - 2J) = c$ , by (6.9) we have that

$$\lim_{J \rightarrow \infty} \frac{c_{J-1-j}^2(1/2)}{2s} = \lim_{J \rightarrow \infty} \frac{N c_{J-1-j}^2(1/2)}{s \cdot 4J} = \frac{\lambda}{\pi},$$

we deduce by employing the normal family argument that the right-hand side of (6.50) converges to

$$\begin{aligned} \frac{\lambda}{\pi} (w - z) \left[ \sum_{j=0}^{\infty} \frac{1 + 2jc^{-1}}{(zw)^{2j+1}} + \sum_{j=0}^{\infty} \frac{1 + (2j+1)c^{-1}}{(zw)^{2j+2}} \right] &= \frac{\lambda}{\pi} \frac{w - z}{zw} \sum_{j=0}^{\infty} \frac{1 + jc^{-1}}{(zw)^j} \\ &= \frac{\lambda}{\pi} \frac{w - z}{zw - 1} \left[ 1 + \frac{c^{-1}}{zw - 1} \right] \end{aligned}$$

locally uniformly in  $\mathbb{O}$ , from which the claim of the theorem easily follows.

**Case  $N = 2J + 1$ :** We get from (5.7) and Lemma 6.11 that

$$\lim_{J \rightarrow \infty} \frac{2}{s - 2J - 1} \frac{\pi_{2J}(z)}{(zw)^{2J+1}} \sum_{j=0}^{J-1} \frac{s_{2j}}{s_{2J}} \pi_{2j+1}(w) = \frac{\lambda}{\pi} \frac{1}{w \sqrt{z^2 - 1} \sqrt{w^2 - 1}}$$

locally uniformly in  $\mathbb{O} \times \mathbb{O}$ . Then, as  $\lim_{J \rightarrow \infty} (s - 2J) = c + 1$  now, it holds that

$$\begin{aligned} \lim_{J \rightarrow \infty} \frac{|zw|^s}{(zw)^{2J+1}} \frac{DS_{2J+1}(z, w)}{s - 2J - 1} &= \lim_{J \rightarrow \infty} \frac{|zw|^s}{(zw)^{2J+1}} \frac{DS_{2J}(z, w)}{s - 2J - 1} + \frac{\lambda}{\pi} \frac{1}{zw} \frac{w - z}{\sqrt{z^2 - 1} \sqrt{w^2 - 1}} \\ &= \frac{\lambda}{\pi} \frac{w - z}{\sqrt{z^2 - 1} \sqrt{w^2 - 1}} \frac{1}{zw} \left[ \frac{1 + c^{-1}}{zw - 1} + \frac{c^{-1}}{(zw - 1)^2} + 1 \right] \end{aligned}$$

locally uniformly in  $\mathbb{O} \times \mathbb{O}$ . Since

$$\frac{1 + c^{-1}}{zw - 1} + \frac{c^{-1}}{(zw - 1)^2} + 1 = \frac{zw}{zw - 1} + \frac{c^{-1}}{zw - 1} + \frac{c^{-1}}{(zw - 1)^2} = \frac{zw}{zw - 1} + \frac{zwc^{-1}}{zw - 1},$$

the theorem follows.  $\square$

For the proof of Theorem 2.9 we shall need the following lemma.

**Lemma 6.12.** *For  $|y| > 1$ , it holds that*

$$\begin{cases} (\epsilon \tilde{\pi}_{2n})(y) &= -\frac{s_{2n}}{2} \xi - \int_{\xi_\infty}^y \tilde{\pi}_{2n}(u) du, \\ (\epsilon \tilde{\pi}_{2n+1})(y) &= -\int_{\xi_\infty}^y \tilde{\pi}_{2n+1}(u) du, \end{cases} \quad (6.51)$$

where  $\xi = \pm 1$  and the numbers  $s_k$  were defined in (4.7).

*Proof.* We start with equation (6.36). Assume  $y > 1$ . Then  $-\int_1^y = -\int_\infty^y - \int_1^\infty$ . It holds by Theorem 4.1, (5.1) and (5.9) that

$$-\int_1^\infty \tilde{\pi}_{2n+1}(u) du = -\frac{1}{4s} P_n^{1/2, -3/2}(1) = -\frac{1}{4s}.$$

To finish the proof of the second equality in (6.51), we only need to observe that, since  $\tilde{\pi}_{2n+1}(u)$  is an odd function,

$$\int_{-\infty}^y \tilde{\pi}_{2n+1}(u)du = \int_{-\infty}^y \tilde{\pi}_{2n+1}(u)du.$$

Analogously, we get that

$$-\int_1^{\infty} \tilde{\pi}_{2n}(u)du = -\left(\int_0^{\infty} - \int_0^1\right) \tilde{\pi}_{2n}(u)du = -\frac{s_{2n}}{2} + 1,$$

where we used the fact that  $\tilde{\pi}_{2n}$  is even, (4.7), and (6.48). Now, since

$$-\int_{-\infty}^y \tilde{\pi}_{2n}(u)du = s_{2n} - \int_{-\infty}^y \tilde{\pi}_{2n}(u)du,$$

the first equality in (6.51) follows. The case  $y < -1$  can be handled similarly.  $\square$

*Proof of Theorem 2.9.* To prove the theorem we need to show that the matrix kernel (1.12) converges to (2.4) with  $A = A_{\mathbb{O}}$  defined by (2.11). Again, we shall utilize (4.5) & (4.6) without mentioning it. Clearly, the case  $u, v \in \mathbb{O} \setminus \mathbb{R}$  follows immediately from Theorem 2.8 (see also (2.8) and (2.10)).

**Case  $N = 2J$ :** According to Lemma 6.12, it holds that

$$\begin{aligned} \mathbf{K}_{2J}^{(1,2)}(z, y) &= -\int_{\xi_y \infty}^y \mathbf{K}_{2J}^{(1,1)}(z, v)dv + \xi_y \sum_{j=0}^{J-1} s_{2j} \tilde{\pi}_{2j+1}(z), \\ \mathbf{K}_{2J}^{(2,2)}(x, y) &= \int_{\xi_x \infty}^x \int_{\xi_y \infty}^y \mathbf{K}_{2J}^{(1,1)}(u, v)dvdu + \left( \xi_x \int_{\xi_y \infty}^y - \xi_y \int_{\xi_x \infty}^x \right) \sum_{j=0}^{J-1} s_{2j} \tilde{\pi}_{2j+1}(u)du, \end{aligned}$$

where  $\xi_u = \text{sgn}(u)$ ,  $u \in \mathbb{R} \setminus \{0\}$ . From Lemma 4.4, we know that

$$s_{2j} = 2(1 + o_s(1)) \sqrt{\frac{s+1}{2}} \frac{\Gamma\left(\frac{s-2j-1}{2}\right)}{\Gamma\left(\frac{s-2j}{2}\right)} \frac{s_{2j}}{s_{2J}},$$

and therefore when  $y \in \mathbb{R}$  and  $\lim_{J \rightarrow \infty} (s - 2J) = c < \infty$  Lemma 6.11 implies

$$\lim_{J \rightarrow \infty} \frac{|zy|^{2J}}{(zy)^{2J}} \sum_{j=0}^{J-1} s_{2j} \tilde{\pi}_{2j+1}(z) = \frac{c-1}{2\sqrt{\pi}} \frac{\Gamma\left(\frac{c-1}{2}\right)}{\Gamma\left(\frac{c}{2}\right)} \frac{1}{|z|^c \sqrt{z^2 - 1}}.$$

Furthermore, the above limit equals zero when  $\lim_{J \rightarrow \infty} (s - 2J) = \infty$ . Since  $|zy|^{2J}/(zy)^{2J} = |zv|^{2J}/(zv)^{2J}$  for  $y, v \in \mathbb{R}$  and  $|uv|^{2J} = (uv)^{2J}$  for  $u, v \in \mathbb{R}$ , the claim of the theorem follows.

**Case  $N = 2J + 1$ :** by Lemma 6.12, it holds that

$$\mathbf{K}_{2J+1}^{(1,2)}(z, y) = \mathbf{K}_{2J}^{(1,2)}(z, y) - \xi_y \sum_{j=0}^{J-1} s_{2j} \tilde{\pi}_{2j+1}(z) - \int_{\xi_y \infty}^y \left( \mathbf{K}_{2J+1}^{(1,1)} - \mathbf{K}_{2J}^{(1,1)} \right) (z, v)dv + \frac{\tilde{\pi}_{2J}(z)}{s_{2J}}. \quad (6.52)$$



Since  $|zy|^{2J+1}/(zy)^{2J+1} = \xi_y |z|^{2J+1}/z^{2J+1} = |zv|^{2J+1}/(zv)^{2J+1}$ , when  $c = \lim_{J \rightarrow \infty} (s - 2J - 1)$ , we deduce from the first part of the proof that

$$\lim_{J \rightarrow \infty} \frac{|zy|^{2J+1}}{(zy)^{2J+1}} \left[ \mathbf{K}_{2J}^{(1,2)}(z, y) - \xi_y \sum_{j=0}^{J-1} s_{2j} \tilde{\pi}_{2j+1}(z) \right] = - \int_{\xi_y \infty}^y \frac{B(z, v)}{zv} dv. \quad (6.53)$$

Furthermore, it holds that

$$\begin{aligned} \frac{|zy|^{2J+1}}{(zy)^{2J+1}} \int_{\xi_y \infty}^y \left( \mathbf{K}_{2J+1}^{(1,1)} - \mathbf{K}_{2J}^{(1,1)} \right) (z, v) dv &= \int_{\xi_y \infty}^y \left( 1 - \frac{1}{zv} \right) \frac{|zv|^{2J+1}}{(zv)^{2J}} \mathbf{K}_{2J}^{(1,1)}(z, v) dv \\ &+ \int_{\xi_y \infty}^y \left( \frac{|zv|^{2J+1}}{(zv)^{2J+1}} \mathbf{K}_{2J+1}^{(1,1)}(z, v) - \frac{|zv|^{2J+1}}{(zv)^{2J}} \mathbf{K}_{2J}^{(1,1)}(z, v) \right) dv, \end{aligned}$$

and therefore

$$\lim_{J \rightarrow \infty} \frac{|zy|^{2J+1}}{(zy)^{2J+1}} \int_{\xi_y \infty}^y \left( \mathbf{K}_{2J+1}^{(1,1)} - \mathbf{K}_{2J}^{(1,1)} \right) (z, v) dv = \int_{\xi_y \infty}^y \left( 1 - \frac{1}{zv} \right) B(z, v) dv. \quad (6.54)$$

It also true that

$$\lim_{J \rightarrow \infty} \frac{|zy|^{2J+1}}{(zy)^{2J+1}} \frac{\tilde{\pi}_{2J}(z)}{s_{2J}} = \frac{\xi_y}{|z|^c \sqrt{z^2 - 1}} \lim_{J \rightarrow \infty} \frac{c_J(1/2)}{s_{2J}} = \frac{1}{\sqrt{\pi}} \frac{\Gamma(\frac{c+1}{2})}{\Gamma(\frac{c}{2})} \frac{\xi_y}{|z|^c \sqrt{z^2 - 1}}. \quad (6.55)$$

Substituting (6.53)–(6.55) into (6.52), we obtain the desired result. Going through the steps above, it is rather straightforward to show that the corresponding limit is zero when  $\lim_{J \rightarrow \infty} (s - 2J) = \infty$ .

Finally, observe that by Lemma 6.12,

$$\begin{aligned} \mathbf{K}_{2J+1}^{(2,2)}(x, y) &= \mathbf{K}_{2J}^{(2,2)}(x, y) + \left( \xi_y \int_{\xi_x \infty}^x - \xi_x \int_{\xi_y \infty}^y \right) \sum_{j=0}^{J-1} s_{2j} \tilde{\pi}_{2j+1}(u) du \\ &+ \int_{\xi_x \infty}^x \int_{\xi_y \infty}^y \left( \mathbf{K}_{2J+1}^{(1,1)} - \mathbf{K}_{2J}^{(1,1)} \right) (u, v) dv du + \left( \int_{\xi_y \infty}^y - \int_{\xi_x \infty}^x \right) \frac{\tilde{\pi}_{2J}(u)}{s_{2J}} du + \frac{\xi_y - \xi_x}{2}. \end{aligned}$$

The last case of the theorem is now proved by doing steps similar to (6.53)–(6.55) and observing that

$$\xi_x \xi_y \left( \frac{\xi_y - \xi_x}{2} + \frac{1}{2} \operatorname{sgn}(x - y) \right) = \frac{1}{2} \operatorname{sgn}(x - y). \quad \square$$

## 6.8 Proof of Theorem 2.1

For the proof of the theorem we shall need several auxiliary computations.

**Lemma 6.13.** *It holds that*

$$\begin{cases} \epsilon \tilde{\pi}_{2n}(y) &= -y P_n^{-1/2, -1/2}(y^2), & |y| \leq 1, \\ \epsilon \tilde{\pi}_{2n+1}(y) &= \frac{y^2}{4s} P_n^{1/2, -3/2}(y^2), & |y| \geq 1. \end{cases}$$

*In particular,  $\epsilon \tilde{\pi}_{2n}(\pm 1) = \mp 1$  and  $\epsilon \tilde{\pi}_{2n+1}(\pm 1) = \frac{1}{4s}$ .*

*Proof.* Evaluating the integrals appearing in the proof of Lemma 6.9, we get that

$$\begin{cases} \epsilon \left( x^{2k} \max \{1, |x|\}^{-s} \right) (y) &= -\frac{y^{2k+1}}{2k+1}, & |y| \leq 1, \\ \epsilon \left( x^{2k+1} \max \{1, |x|\}^{-s} \right) (y) &= \frac{|y|^{2k+2-s}}{s-2k-2}, & |y| \geq 1. \end{cases}$$

Thus, the formula for  $\epsilon \tilde{\pi}_{2n}(y)$  follows from (4.4) & (5.1) and the fact that  $(2k+1)c_k(-1/2) = c_k(1/2)$ , see (6.8) for the definition of these constants. Moreover, we can rewrite the formula for  $\pi_{2n+1}$  in Theorem 4.1 as

$$\pi_{2n+1}(z) = \frac{1}{4s} \sum_{k=0}^n (s-2k-2)c_k(1/2)c_{n-k}(-3/2)x^{2k+1}$$

from which formula for  $\epsilon \tilde{\pi}_{2n+1}(y)$  easily follows. The final claim of the lemma is an immediate consequence of Proposition 5.6.  $\square$

**Lemma 6.14.** *For  $x > -1$ , it holds that*

$$\sum_{m=0}^M \frac{\Gamma(m+1/2)}{\Gamma(m+1)} \frac{\Gamma(M-m+1+x)}{\Gamma(M-m+5/2+x)} = \frac{4}{2M+3+2x} \frac{\Gamma(M+3/2)}{\Gamma(M+1)} \frac{\Gamma(1+x)}{\Gamma(3/2+x)}.$$

*Proof.* The case  $M=0$  is elementary. Thus, it only remains to complete the inductive step. The sum we are computing is equal to

$$\sum_{m=0}^{M-1} \frac{\Gamma(m+1/2)}{\Gamma(m+1)} \frac{\Gamma(M-1-m+1+x+1)}{\Gamma(M-1-m+5/2+x+1)} + \frac{\Gamma(M+1/2)}{\Gamma(M+1)} \frac{\Gamma(1+x)}{\Gamma(5/2+x)}$$

and, by the inductive hypothesis, to

$$\frac{4}{2(M-1)+3+2(x+1)} \frac{\Gamma(M+1/2)}{\Gamma(M)} \frac{\Gamma(1+x)}{\Gamma(5/2+x)} + \frac{\Gamma(M+1/2)}{\Gamma(M+1)} \frac{\Gamma(1+x)}{\Gamma(5/2+x)}$$

and hence to

$$\frac{4}{2M+3+2x} \frac{\Gamma(M+1/2)}{\Gamma(M+1)} \frac{\Gamma(1+x)}{\Gamma(5/2+x)} \left[ M(1+x) + \frac{2M+3+2x}{4} \right].$$

This finishes the proof as the term in square brackets factors as  $(M+1/2)(3/2+x)$ .  $\square$

**Lemma 6.15.** *It holds for  $x > 0$  that*

$$\sum_{j=0}^{J-1} \frac{\Gamma(j+1/2)}{\Gamma(j+1)} \frac{\Gamma(j+x)}{\Gamma(j+3/2+x)} = \frac{2}{x} \frac{\Gamma(J+1/2)}{\Gamma(J)} \frac{\Gamma(J+x)}{\Gamma(J+1/2+x)}.$$

*Proof.* The case  $J=1$  is trivial. Thus, we need only to show the inductive step. The sum we are computing is equal to

$$\sum_{j=0}^{J-2} \frac{\Gamma(j+1/2)}{\Gamma(j+1)} \frac{\Gamma(j+x)}{\Gamma(j+3/2+x)} + \frac{\Gamma(J-1/2)}{\Gamma(J)} \frac{\Gamma(J-1+x)}{\Gamma(J+1/2+x)},$$

which, by the inductive hypothesis, can be written as

$$\frac{2}{x} \frac{\Gamma(J-1/2)}{\Gamma(J-1)} \frac{\Gamma(J-1+x)}{\Gamma(J-1/2+x)} + \frac{\Gamma(J-1/2)}{\Gamma(J)} \frac{\Gamma(J-1+x)}{\Gamma(J+1/2+x)},$$

which, in turn, is equal to

$$\frac{2}{x} \frac{\Gamma(J-1/2)}{\Gamma(J)} \frac{\Gamma(J-1+x)}{\Gamma(J+1/2+x)} \left[ (J-1) \left( J - \frac{1}{2} + x \right) + \frac{x}{2} \right].$$

As the term in square brackets factors as  $(J-1/2)(J-1+x)$ , the proof of the lemma is complete.  $\square$

*Proof of Theorem 2.1. Case  $N = 2J$ :* For a measurable set  $A \subseteq \mathbb{R}$ , denote by  $N_A$  the number of real roots of a random polynomial of degree  $N$  from the real Mahler ensemble that belong to  $A$ . It follows from (1.9), (1.11), (1.12), and (4.5) that

$$\begin{aligned} E[N_A] &= \int_A \text{Pf} [\mathbf{K}_N(x, x)] d\mu_{\mathbb{R}}(x) = \int_A \text{Pf} \begin{bmatrix} 0 & \varkappa_N \epsilon(x, x) \\ \epsilon \varkappa_N(x, x) & 0 \end{bmatrix} d\mu_{\mathbb{R}}(x) \\ &= \sum_{n=0}^{J-1} \int_A 2[\tilde{\pi}_{2n}(x) \epsilon \tilde{\pi}_{2n+1}(x) - \tilde{\pi}_{2n+1}(x) \epsilon \tilde{\pi}_{2n}(x)] d\mu_{\mathbb{R}}(x). \end{aligned} \quad (6.56)$$

Let  $A = [-1, 1]$ , where we abbreviate  $N_{\text{in}} = N_{[-1, 1]}$ . Recall that for  $x \in [-1, 1]$ ,  $\tilde{\pi}_k(x) = \pi_k(x)$ . Further, since  $\epsilon$  operator for real arguments essentially amounts to anti-differentiation, see the paragraph after Theorem 1.4, we also have that  $(\epsilon \tilde{\pi}_k)'(x) = -\tilde{\pi}_k(x)$ . Therefore,

$$\begin{aligned} E[N_{\text{in}}] &= \sum_{n=0}^{J-1} \left[ -2\epsilon \tilde{\pi}_{2n+1}(x) \epsilon \tilde{\pi}_{2n}(x) \Big|_{-1}^1 - 4 \int_{-1}^1 \pi_{2n+1}(x) \epsilon \tilde{\pi}_{2n}(x) d\mu_{\mathbb{R}}(x) \right] \\ &=: Js^{-1} + \sum_{n=0}^{J-1} I_n, \end{aligned} \quad (6.57)$$

where we used the second conclusion of Lemma 6.13. Appealing to Lemma 6.13 once more, as well as to Theorem 4.1, we obtain that  $I_n$  equals

$$\frac{1}{\pi s} \sum_{m=0}^n \frac{\Gamma(m+1/2)}{\Gamma(m+1)} \frac{\Gamma(n-m+1/2)}{\Gamma(n-m+1)} \left[ -\frac{2}{\pi} \sum_{k=0}^n \frac{\Gamma(k+3/2)}{\Gamma(k+1)} \frac{\Gamma(n-k-1/2)}{\Gamma(n-k+1)} \frac{s-2k-2}{2k+2m+3} \right].$$

Since  $s-2k-2 = -(2k+2m+3) + (s+2m+1)$  and applying Lemma 6.1 with  $a = 3/2$ ,  $b = -1/2$ , and  $x = -m-1$ , we see that the term in square brackets from the above equation is equal to

$$-2P_n^{1/2, -3/2}(1) - (s+2m+1) \frac{(-(m+1)) \cdots (-(m+1) - (n-1))}{(-(m+3/2)) \cdots (-(m+3/2) - n)}.$$

As  $P_n^{1/2, -3/2}(1) = P_n^{-1/2, -1/2}(1) = 1$  by Proposition 5.6, we further get that

$$I_n = -\frac{2}{s} + \frac{1}{\pi s} \sum_{m=0}^n (s+2m+1) \frac{\Gamma(m+1/2)}{\Gamma(m+1)} \frac{\Gamma(n-m+1/2)}{\Gamma(n-m+1)} \frac{\Gamma(n+m+1)}{\Gamma(n+m+5/2)} \frac{\Gamma(m+3/2)}{\Gamma(m+1)}. \quad (6.58)$$

Observe that

$$\frac{\Gamma(m+1/2)\Gamma(m+3/2)}{\Gamma(m+1)\Gamma(m+1)} = 1 + O\left(\frac{1}{m+1}\right)$$

by (6.9). Thus, upon replacing  $m$  by  $n-m$ , we get that

$$I_n = -\frac{2}{s} + \frac{1}{\pi s} \sum_{m=0}^n \left(1 + O\left(\frac{1}{n-m+1}\right)\right) [s+2n+2-2m-1] \frac{\Gamma(m+1/2)}{\Gamma(m+1)} \frac{\Gamma(2n-m+1)}{\Gamma(2n-m+5/2)}.$$

It follows from Lemma 6.14 applied with  $M = n$  and  $x = M$  that

$$\sum_{m=0}^n \frac{\Gamma(m+1/2)}{\Gamma(m+1)} \frac{\Gamma(2n-m+1)}{\Gamma(2n-m+5/2)} = \frac{4}{4n+3}$$

and therefore

$$\sum_{m=0}^n \left(1 + O\left(\frac{1}{n-m+1}\right)\right) \frac{\Gamma(m+1/2)}{\Gamma(m+1)} \frac{\Gamma(2n-m+1)}{\Gamma(2n-m+5/2)} = \frac{4}{4n+3} + O\left(\frac{\log n}{(n+1)^{3/2}}\right),$$

where the term  $O(\cdot)$  follows from the estimates

$$\frac{\Gamma(m+1/2)}{\Gamma(m+1)} \frac{\Gamma(2n-m+1)}{\Gamma(2n-m+5/2)} \leq \frac{\Gamma(n+1)}{\Gamma(n+5/2)}.$$

Thus, we deduce that

$$I_n = \frac{s+2n+2}{\pi s} \left( \frac{4}{4n+3} + O\left(\frac{\log n}{(n+1)^{3/2}}\right) \right) - \frac{2}{s} - \frac{2}{\pi} \sum_{m=0}^n (1 + o_{n-m}(1)) \frac{\Gamma(m+3/2)}{\Gamma(m+1)} \frac{\Gamma(2n-m+1)}{\Gamma(2n-m+5/2)}.$$

Using the monotonicity of the second fraction in the sum above once more and since

$$\sum_{m=0}^n \frac{\Gamma(m+3/2)}{\Gamma(m+1)} = \frac{2}{3} \frac{\Gamma(n+5/2)}{\Gamma(n+1)},$$

it holds that

$$\frac{2}{3} \frac{\Gamma(n+5/2)}{\Gamma(n+1)} \frac{\Gamma(2n+1)}{\Gamma(2n+5/2)} \leq \sum_{m=0}^n \frac{\Gamma(m+3/2)}{\Gamma(m+1)} \frac{\Gamma(2n-m+1)}{\Gamma(2n-m+5/2)} \leq \frac{2}{3}.$$

It now easily follows from (6.9) that

$$I_n = \frac{1}{\pi} \left( \frac{1}{n+3/4} + O\left(\frac{\log n}{(n+1)^{3/2}}\right) \right) + \frac{\{\text{a term, which is uniformly bounded with } n\}}{s}.$$

By plugging the above expression into (6.57), we obtain the first claim of the theorem.

Let now  $A = \mathbb{R} \setminus (-1, 1)$ , in which case we abbreviate  $N_{\text{out}} = N_{\mathbb{R} \setminus (-1, 1)}$ . As the integrand of (6.56) is an even function of  $x$ , we can write

$$\begin{aligned} E[N_{\text{out}}] &= \sum_{n=0}^{J-1} \left[ 4\epsilon \tilde{\pi}_{2n+1}(x) \tilde{\pi}_{2n}(x) \Big|_1^\infty + 8 \int_1^\infty \epsilon \tilde{\pi}_{2n+1}(x) \tilde{\pi}_{2n}(x) d\mu_{\mathbb{R}}(x) \right] \\ &=: Js^{-1} + \sum_{n=0}^{J-1} I_{n,s}, \end{aligned} \tag{6.59}$$

where we used the second conclusion of Lemma 6.13 once more. As before, by appealing to Lemma 6.13 and Theorem 4.1, we deduce that  $I_{n,s}$  equals

$$\frac{2}{\pi s} \sum_{i=0}^n \frac{\Gamma(i+3/2)}{\Gamma(i+1)} \frac{\Gamma(n-i+1/2)}{\Gamma(n-i+1)} \left[ -\frac{1}{\pi} \sum_{k=0}^n \frac{\Gamma(k+3/2)}{\Gamma(k+1)} \frac{\Gamma(n-k-1/2)}{\Gamma(n-k+1)} \frac{1}{s-i-k-3/2} \right].$$

The term in square brackets can be summed up using Lemma 6.1 applied with  $a = 3/2$ ,  $b = -1/2$ , and  $x = s - i - 1$ , to yield

$$I_{n,s} = \frac{2}{\pi s} \sum_{i=0}^n \frac{\Gamma(i+3/2)}{\Gamma(i+1)} \frac{\Gamma(n-i+1/2)}{\Gamma(n-i+1)} \frac{\Gamma(s-i)}{\Gamma(s-i-1/2)} \frac{\Gamma(s-i-n-3/2)}{\Gamma(s-i-n)}. \quad (6.60)$$

By plugging the above expression into (6.59) we get

$$E[N_{\text{out}}] = Js^{-1} + \frac{2}{\pi s} \sum_{i=0}^{J-1} \frac{\Gamma(i+3/2)}{\Gamma(i+1)} \frac{\Gamma(s-i)}{\Gamma(s-i-1/2)} \sum_{n=i}^{J-1} \frac{\Gamma(n-i+1/2)}{\Gamma(n-i+1)} \frac{\Gamma(s-i-n-3/2)}{\Gamma(s-i-n)}.$$

Since

$$\sum_{n=i}^{J-1} \frac{\Gamma(n-i+1/2)}{\Gamma(n-i+1)} \frac{\Gamma(s-i-n-3/2)}{\Gamma(s-i-n)} = \sum_{m=0}^{J-1-i} \frac{\Gamma(m+1/2)}{\Gamma(m+1)} \frac{\Gamma(s-2i-m-3/2)}{\Gamma(s-2i-m)},$$

we get from Lemma 6.14 applied with  $M = J - 1 - i$  and  $x = s - J - i - 3/2$  that

$$\begin{aligned} E[N_{\text{out}}] &= Js^{-1} + \frac{2}{\pi s} \sum_{i=0}^{J-1} \frac{\Gamma(i+3/2)\Gamma(s-i)\Gamma(s-J-i-1/2)\Gamma(J-i+1/2)}{\Gamma(i+1)\Gamma(s-i-1/2)\Gamma(s-J-i)\Gamma(J-i)} \frac{2}{s-1-2i} \\ &= Js^{-1} + \frac{2}{\pi s} \sum_{m=0}^{J-1} \frac{\Gamma(J-m+1/2)\Gamma(s-J+m+1)\Gamma(\Delta+m-1/2)\Gamma(m+3/2)}{\Gamma(J-m)\Gamma(s-J+m+1/2)\Gamma(\Delta+m)\Gamma(m+1)} \frac{1}{m+\Delta/2}, \end{aligned}$$

where  $\Delta := s - N + 1$ . Using (6.9), we can rewrite the sum above as

$$\frac{2}{\pi s} \sum_{m=0}^{J-1} \frac{\Gamma(J-m+1/2)}{\Gamma(J-m)} \frac{\Gamma(s-J+m+1)}{\Gamma(s-J+m+1/2)} \sqrt{\frac{m+1}{m+\Delta}} \left( 1 + O\left(\frac{1}{m+1}\right) \right) \frac{1}{m+\Delta/2}.$$

Since

$$\sqrt{\frac{m+1}{m+\Delta}} \frac{\Gamma(J-m+1/2)}{\Gamma(J-m)} \frac{\Gamma(s-J+m+1)}{\Gamma(s-J+m+1/2)} \leq \frac{\Gamma(J+1/2)}{\Gamma(J)} \frac{\Gamma(s)}{\Gamma(s-1/2)},$$

we have that

$$\begin{aligned} \frac{2}{\pi s} \sum_{m=0}^{J-1} \frac{\Gamma(J-m+1/2)}{\Gamma(J-m)} \frac{\Gamma(s-J+m+1)}{\Gamma(s-J+m+1/2)} \sqrt{\frac{m+1}{m+\Delta}} O\left(\frac{1}{m+1}\right) \frac{1}{m+\Delta/2} \\ = \sqrt{Ns^{-1}} O_N(1), \end{aligned}$$

and therefore

$$E[N_{\text{out}}] = \sqrt{Ns^{-1}} O_N(1) + \frac{2}{\pi s} \sum_{m=0}^{J-1} \frac{\Gamma(J-m+1/2)}{\Gamma(J-m)} \frac{\Gamma(s-J+m+1)}{\Gamma(s-J+m+1/2)} \sqrt{\frac{m+1}{m+\Delta}} \frac{1}{m+\Delta/2}.$$

Furthermore, as

$$1 - \sqrt{\frac{m+1}{m+\Delta}} = \frac{\Delta-1}{\sqrt{m+\Delta}(\sqrt{m+\Delta} + \sqrt{m+1})} \leq \frac{\Delta}{m+\Delta/2},$$

and since, estimating as before,

$$\frac{2}{\pi s} \sum_{m=0}^{J-1} \frac{\Gamma(J-m+1/2)}{\Gamma(J-m)} \frac{\Gamma(s-J+m+1)}{\Gamma(s-J+m+1/2)} \frac{\Delta}{(m+\Delta/2)^2} \leq \sqrt{Ns^{-1}} O_N(1) \int_0^\infty \frac{\Delta dx}{(x+\Delta/2)^2},$$

where the integral is equal to 2, we have that

$$E[N_{\text{out}}] = \sqrt{Ns^{-1}} O_N(1) + \frac{2}{\pi s} \sum_{m=0}^{J-1} \frac{\Gamma(J-m+1/2)}{\Gamma(J-m)} \frac{\Gamma(s-J+m+1)}{\Gamma(s-J+m+1/2)} \frac{1}{m+\Delta/2}.$$

Continuing on the path of estimates, observe that

$$\frac{\Gamma(J-m+1/2)}{\Gamma(J-m)} \frac{\Gamma(s-J+m+1)}{\Gamma(s-J+m+1/2)} = \sqrt{(J-m)(s-J+m)} \left(1 + O\left(\frac{1}{J-m}\right)\right)$$

by (6.9). As  $s-J = \Delta + J - 1$  and respectively

$$\frac{\sqrt{s-J+m}}{m+\Delta/2} \sqrt{(J-m)} O\left(\frac{1}{J-m}\right) \leq O\left(\sqrt{\frac{J}{J-m}}\right),$$

we get that

$$\frac{2}{\pi s} \sum_{m=0}^{J-1} \sqrt{(J-m)(s-J+m)} O\left(\frac{1}{J-m}\right) \frac{1}{m+\Delta/2} \leq Ns^{-1} O_N(1)$$

and therefore

$$E[N_{\text{out}}] = \sqrt{Ns^{-1}} O_N(1) + \frac{2}{\pi s} \sum_{m=0}^{J-1} \sqrt{(J-m)(s-J+m)} \frac{1}{m+\Delta/2}.$$

Now, it holds that

$$\sqrt{J(s-J)} - \sqrt{(J-m)(s-J+m)} = \frac{m(m-1+\Delta)}{\sqrt{J(s-J)} + \sqrt{(J-m)(s-J+m)}} \leq \frac{m(2m+\Delta)}{\sqrt{J(s-J)}}$$

and that

$$\frac{2}{\pi s} \sum_{m=0}^{J-1} \frac{m(2m+\Delta)}{\sqrt{J(s-J)}} \frac{1}{m+\Delta/2} = \frac{1}{\pi} \frac{\sqrt{J}(J-1)}{s\sqrt{s-J}} \leq \frac{1}{\pi} Js^{-1},$$

where we used the fact that  $s-J > J$ . Hence,

$$E[N_{\text{out}}] = \sqrt{Ns^{-1}} O_N(1) + \frac{2}{\pi} \frac{\sqrt{J(s-J)}}{s} \sum_{m=0}^{J-1} \frac{1}{m+\Delta/2}.$$

Finally, it only remains to notice that

$$\sum_{m=1}^J \frac{1}{m + \Delta/2} \leq \int_0^J \frac{dx}{x + \Delta/2} \leq \sum_{m=0}^{J-1} \frac{1}{m + \Delta/2},$$

which yields that

$$\sum_{m=0}^{J-1} \frac{1}{m + \Delta/2} = \log(N + \Delta) - \log \Delta + O_N(1) = -\log(1 - Ns^{-1}) + O_N(1).$$

**Case  $N = 2J + 1$ :** It follows from (4.6) that to prove the asymptotic formula for  $E[N_{\text{in}}]$ , we need to show that

$$\int_{-1}^1 \left( -2 \sum_{n=0}^{J-1} \frac{s_{2n}}{s_{2J}} [\tilde{\pi}_{2J}(x)\epsilon\tilde{\pi}_{2n+1}(x) - \epsilon\tilde{\pi}_{2J}(x)\tilde{\pi}_{2n+1}(x)] + \frac{\tilde{\pi}_{2J}(x)}{s_{2J}} \right) d\mu_{\mathbb{R}}(x) = O_N(1). \quad (6.61)$$

One can explicitly compute exactly as in Lemma 6.13 that

$$s_{2J}^{-1} \int_{-1}^1 \tilde{\pi}_{2J}(x) d\mu_{\mathbb{R}}(x) = 2s_{2J}^{-1} P_J^{-1/2, -1/2}(1) = 2s_{2J}^{-1} = \frac{\Gamma\left(\frac{s+1}{2}\right) \Gamma\left(\frac{s-N+1}{2}\right)}{\Gamma\left(\frac{s+2}{2}\right) \Gamma\left(\frac{s-N}{2}\right)} \leq 1 \quad (6.62)$$

by Proposition 5.6, the definition  $s_{2J}$ , see (4.7), and (6.9). To estimate the remaining part of the integral observe that

$$2 \int_{-1}^1 (\tilde{\pi}_{2J}(x)\epsilon\tilde{\pi}_{2n+1}(x) - \epsilon\tilde{\pi}_{2J}(x)\tilde{\pi}_{2n+1}(x)) d\mu_{\mathbb{R}}(x) = \frac{1}{s} - 4 \int_{-1}^1 \epsilon\tilde{\pi}_{2J}(x)\tilde{\pi}_{2n+1}(x) d\mu_{\mathbb{R}}(x)$$

exactly as in (6.57). Moreover, as in (6.58), we have that the above quantity is equal to

$$-\frac{1}{s} + \frac{1}{\pi s} \sum_{m=0}^J (s+2m+1) \frac{\Gamma(m+1/2) \Gamma(J-m+1/2)}{\Gamma(m+1)} \frac{\Gamma(n+m+1)}{\Gamma(J-m+1)} \frac{\Gamma(n+m+1)}{\Gamma(n+m+5/2)} \frac{\Gamma(m+3/2)}{\Gamma(m+1)}. \quad (6.63)$$

Observe that

$$\sum_{m=0}^J \frac{\Gamma(J-m+1/2)}{\Gamma(J-m+1)} \frac{\Gamma(n+m+1)}{\Gamma(n+m+5/2)} = \frac{4}{2(J+n)+3} \frac{\Gamma(J+3/2)}{\Gamma(J+1)} \frac{\Gamma(n+1)}{\Gamma(n+3/2)} \leq \frac{O_N(1)}{\sqrt{J(n+1)}}$$

by performing the substitution  $m \mapsto J-m$  and applying Lemma 6.14 with  $M = J$  and  $x = n$ , as well as by using (6.9). Since

$$\frac{s+2m+1}{\pi s} \frac{\Gamma(m+1/2)}{\Gamma(m+1)} \frac{\Gamma(m+3/2)}{\Gamma(m+1)} = O(1),$$

the sum in (6.63) is bounded by a constant times  $1/\sqrt{J(n+1)}$ . As the numbers  $s_{2n}$  increase with  $n$  and hence  $s_{2n}/s_{2J} \leq 1$  for  $n \leq J$ , and since  $\sum_{n=0}^{J-1} 1/\sqrt{J(n+1)} = O_N(1)$ , we see that (6.61) indeed takes place.

To prove the asymptotic formula for  $E[N_{\text{out}}]$ , we need to show that

$$\int_{\mathbb{R} \setminus (-1,1)} \left( -2 \sum_{n=0}^{J-1} \frac{s_{2n}}{s_{2J}} [\tilde{\pi}_{2J}(x)\epsilon\tilde{\pi}_{2n+1}(x) - \epsilon\tilde{\pi}_{2J}(x)\tilde{\pi}_{2n+1}(x)] + \frac{\tilde{\pi}_{2J}(x)}{s_{2J}} \right) d\mu_{\mathbb{R}}(x) = \sqrt{Ns^{-1}} O_N(1). \quad (6.64)$$

We immediately deduce from the definition of  $s_{2J}$  and (6.62) that

$$s_{2J}^{-1} \int_{\mathbb{R} \setminus (-1,1)} \tilde{\pi}_{2J}(x) d\mu_{\mathbb{R}}(x) = 1 - \frac{\Gamma\left(\frac{s+1}{2}\right) \Gamma\left(\frac{s-N+1}{2}\right)}{\Gamma\left(\frac{s+2}{2}\right) \Gamma\left(\frac{s-N}{2}\right)} = N s^{-1} O_N(1),$$

where, as usual, we used (6.9). Further, we have as in (6.59) that

$$\begin{aligned} 2 \int_{\mathbb{R} \setminus (-1,1)} (\tilde{\pi}_{2J}(x) \epsilon \tilde{\pi}_{2n+1}(x) - \epsilon \tilde{\pi}_{2J}(x) \tilde{\pi}_{2n+1}(x)) d\mu_{\mathbb{R}}(x) \\ = \frac{1}{s} + 8 \int_1^{\infty} \epsilon \tilde{\pi}_{2n+1}(x) \tilde{\pi}_{2J}(x) d\mu_{\mathbb{R}}(x). \end{aligned}$$

The same computation as in (6.60) tells us that we need to estimate the quantity

$$\frac{2}{\pi s} \sum_{n=0}^{J-1} \frac{s_{2n}}{s_{2J}} \sum_{i=0}^J \frac{\Gamma(i+3/2) \Gamma(J-i+1/2)}{\Gamma(i+1) \Gamma(J-i+1)} \frac{\Gamma(s-i)}{\Gamma(s-i-1/2)} \frac{\Gamma(s-i-n-3/2)}{\Gamma(s-i-n)}, \quad (6.65)$$

where we dispensed with the term  $\sum_{n=0}^{J-1} \frac{s_{2n}}{s_{2J}} \frac{1}{s}$  as it is bounded above by  $J s^{-1}$ . Since  $s > 2J$ , we have that

$$\begin{aligned} \sum_{n=0}^{J-1} \frac{\Gamma\left(\frac{s-1}{2} - n\right) \Gamma(s-i-n-3/2)}{\Gamma\left(\frac{s}{2} - n\right) \Gamma(s-i-n)} &\leq \sum_{n=0}^{J-1} \frac{\Gamma(J-n-1/2) \Gamma(s-i-n-3/2)}{\Gamma(J-n) \Gamma(s-i-n)} \\ &= \sum_{j=0}^{J-1} \frac{\Gamma(j+1/2) \Gamma(j+s-J-i-1/2)}{\Gamma(j+1) \Gamma(j+s-J-i+1)} \\ &= \frac{2}{s-J-i-1/2} \frac{\Gamma(J+1/2) \Gamma(s-i-1/2)}{\Gamma(J) \Gamma(s-i)} \end{aligned}$$

by Lemma 6.15 applied with  $x = s - J - i - 1/2$ . Hence, (6.65) is bounded above by

$$\frac{2}{\pi s} \frac{\Gamma(J+1/2) \Gamma\left(\frac{s-N+1}{2}\right)}{\Gamma(J) \Gamma\left(\frac{s-N}{2}\right)} \sum_{i=0}^J \frac{\Gamma(i+3/2) \Gamma(J-i+1/2)}{\Gamma(i+1) \Gamma(J-i+1)} \frac{2}{s-J-i-1/2}$$

and respectively, upon replacing  $s$  by  $2J$ , it is bounded above by

$$\frac{4}{\pi s} \frac{\Gamma(J+1/2) \Gamma\left(\frac{s-N+1}{2}\right)}{\Gamma(J) \Gamma\left(\frac{s-N}{2}\right)} \sum_{i=0}^J \frac{\Gamma(i+3/2) \Gamma(J-i-1/2)}{\Gamma(i+1) \Gamma(J-i+1)} \ll \frac{\sqrt{N(s-N)}}{s},$$

where we used (6.9) and the fact that the sum on the left-hand side of the above inequality is nothing else but  $P_J^{1/2, -3/2}(1)$ , which is equal to 1 according to Proposition 5.6. This finishes the proof of (6.64) and therefore of the theorem.  $\square$

## 7 Acknowledgments

This paper was many years in the making, and the first author (CDS) talked with a number of people during the course of its development. Firstly, we thank Alexei Borodin and



Percy Deift for enlightening early conversations (this was before the derivation of the skew-orthogonal polynomials and kernel asymptotics for Ginibre’s real ensemble, and before I knew anything of random matrices, matrix kernels and the ilk; Alexei and Percy were very patient in guiding me down this path). We also thank Brian Rider who has visited this problem with us on and off over the last half dozen years. Since this problem is ultimately a spin-off of the first author’s thesis, albeit one very far from the original intentions of said thesis, we would be remiss if we did not thank Jeff Vaaler for many years of helpful and encouraging conversations revolving around Mahler’s measure and its various star bodies.

## A Random Normal Matrices

Normal matrices are square matrices which commute with their adjoints. That is, a matrix  $\mathbf{Z} \in \mathbb{C}^{N \times N}$  is normal if  $\mathbf{Z}\mathbf{Z}^* = \mathbf{Z}^*\mathbf{Z}$ . By the spectral theorem, if  $\mathbf{Z}$  is normal, there exist a unitary  $N \times N$  matrix  $\mathbf{U}$  and a diagonal matrix  $\mathbf{\Lambda}$  such that

$$\mathbf{Z} = \mathbf{U}^* \mathbf{\Lambda} \mathbf{U}. \tag{A.1}$$

Given a normal matrix  $\mathbf{X} \in \mathbb{R}^{N \times N}$ , there exists an orthogonal matrix  $\mathbf{O}$  and a block diagonal matrix  $\mathbf{\Gamma}$  such that

$$\mathbf{X} = \mathbf{O}^T \mathbf{\Gamma} \mathbf{O}, \quad \text{where} \quad \mathbf{\Gamma} = \begin{bmatrix} \alpha_1 & & & & & \\ & \ddots & & & & \\ & & \alpha_L & & & \\ & & & \mathbf{B}_1 & & \\ & & & & \ddots & \\ & & & & & \mathbf{B}_M \end{bmatrix}, \tag{A.2}$$

and the  $\alpha_\ell \in \mathbb{R}$  and the  $\mathbf{B}_m \in \mathbb{R}^{2 \times 2}$  are of the form

$$\mathbf{B}_m = \begin{bmatrix} x_m & y_m \\ -y_m & x_m \end{bmatrix}.$$

Clearly, in this situation,  $L + 2M = N$ .

We will denote the set of complex normal matrices by  $\mathcal{N}_N(\mathbb{C})$  and the set of real normal matrices by  $\mathcal{N}_N(\mathbb{R})$ .  $\mathcal{N}_N(\mathbb{C})$  and  $\mathcal{N}_N(\mathbb{R})$  are naturally embedded in  $\mathbb{C}^{N \times N}$  and  $\mathbb{R}^{N \times N}$  respectively. The canonical metrics on  $\mathbb{C}^{N \times N}$  and  $\mathbb{R}^{N \times N}$  induce metrics on  $\mathcal{N}_N(\mathbb{C})$  and  $\mathcal{N}_N(\mathbb{R})$ , and from these induced metrics we arrive at natural volume forms in these sets. These volume forms in turn induce measures on  $\mathcal{N}_N(\mathbb{C})$  and  $\mathcal{N}_N(\mathbb{R})$  which we will denote by  $\theta_{\mathbb{C}}$  and  $\theta_{\mathbb{R}}$  respectively.

Equations (A.1) and (A.2) yield *spectral parametrizations* of  $\mathcal{N}_N(\mathbb{C})$  and  $\mathcal{N}_N(\mathbb{R})$ —the coordinates of which we refer to as *spectral variables*. Among the spectral variables are those which represent the eigenvalues of normal matrices. The remaining variables are derived from the eigenvectors. In the case of  $\mathcal{N}_N(\mathbb{C})$  we may produce a canonical measure  $\xi_N$  on the sets of eigenvalues (as identified with  $\mathbb{C}^N$ ) by integrating the pull back of  $\theta_{\mathbb{C}}$  under the spectral parametrization with respect to the eigenvalue coordinates over the entire unitary group. This removes any dependency of the measure  $\theta_{\mathbb{C}}$  on  $\mathbf{U}$ , and what we find is that  $\xi_N$  encodes the local behavior of sets of eigenvalues of matrices in  $\mathcal{N}_N(\mathbb{C})$ . As we shall

see,  $\xi_N$  is absolutely continuous with respect to Lebesgue measure on  $\mathbb{C}^N$  and its Radon-Nikodym derivative is the familiar-looking Vandermonde term which demonstrates how the eigenvalues of random normal matrices tend to repel each other.

We may likewise produce a canonical measure on the set of eigenvalues of real normal matrices as identified with

$$\bigcup_{\substack{(L,M) \\ L+2M=N}} \mathbb{R}^L \times \mathbb{C}^M.$$

For a particular pair  $(L, M)$  such that  $L + 2M = N$ , we will call  $\mathbb{R}^L \times \mathbb{C}^M$  a *sector* of the space of eigenvalues. In the case of real normal ensembles, the canonical measure on the set of eigenvalues induces measures  $\xi_{L,M}$  on each of the sectors  $\mathbb{R}^L \times \mathbb{C}^M$ , and we shall see that  $\xi_{L,M}$  is absolutely continuous with respect to Lebesgue measure on  $\mathbb{R}^L \times \mathbb{C}^M$ . As in the case of  $\mathcal{N}_N(\mathbb{C})$ , the Radon-Nikodym derivative of  $\xi_{L,M}$  with respect to Lebesgue measure on  $\mathbb{R}^L \times \mathbb{C}^M$  demonstrates repulsion among the eigenvalues of random real normal matrices.

## A.1 The Spectral Parametrization and the Induced Measure on Eigenvalues

### A.1.1 Complex Normal Matrices

The joint density of eigenvalues of complex normal matrices [?] is well known, but we recall the derivation here as it motivates the discussion of real normal matrices. See also [?] for an exposition on calculations of this flavor.

$\mathcal{N}_N(\mathbb{C})$  inherits the Hermitian metric from  $\mathbb{C}^{N \times N}$  given by  $\text{Tr}(d\mathbf{Z} d\mathbf{Z}^*)$  where

$$\mathbf{Z} = [z_{m,n}]_{m,n=1}^N \quad \text{and} \quad d\mathbf{Z} = [dz_{m,n}]_{m,n=1}^N.$$

First we write

$$\text{Tr}(d\mathbf{Z} d\mathbf{Z}^*) = \text{Tr}(\mathbf{U}^* \mathbf{U} d\mathbf{Z} \mathbf{U}^* \mathbf{U} d\mathbf{Z}^*) = \text{Tr}(\mathbf{U} d\mathbf{Z} \mathbf{U}^* \mathbf{U} d\mathbf{Z}^* \mathbf{U}^*).$$

Using the change of variables (A.1), we have

$$\mathbf{U} d\mathbf{Z} \mathbf{U}^* = d\mathbf{\Lambda} + \mathbf{U} d\mathbf{U}^* \mathbf{\Lambda} + \mathbf{\Lambda} d\mathbf{U} \mathbf{U}^*.$$

Since  $\mathbf{U} \mathbf{U}^* = \mathbf{I}$ ,

$$d\mathbf{S} := \mathbf{U} d\mathbf{U}^* = -d\mathbf{U} \mathbf{U}^*,$$

and hence

$$\mathbf{U} d\mathbf{Z} \mathbf{U}^* = d\mathbf{\Lambda} + d\mathbf{S} \mathbf{\Lambda} - \mathbf{\Lambda} d\mathbf{S} = d\mathbf{\Lambda} + [d\mathbf{S}, \mathbf{\Lambda}],$$

where the brackets in the latter expression represent the commutator. Clearly then,

$$\mathbf{U} d\mathbf{Z} \mathbf{U}^* \mathbf{U} d\mathbf{Z}^* \mathbf{U}^* = d\mathbf{\Lambda} d\mathbf{\Lambda}^* + [d\mathbf{S}, \mathbf{\Lambda}] d\mathbf{\Lambda}^* + d\mathbf{\Lambda} [d\mathbf{S}, \mathbf{\Lambda}^*] + [d\mathbf{S}, \mathbf{\Lambda}] [d\mathbf{S}, \mathbf{\Lambda}^*].$$

It is easily seen that  $\text{Tr} [d\mathbf{S}, \mathbf{\Lambda}] = 0$  and therefore  $\text{Tr} ([d\mathbf{S}, \mathbf{\Lambda}] d\mathbf{\Lambda}^*) = 0$ . By similar reasoning,  $\text{Tr} (d\mathbf{\Lambda} [d\mathbf{S}, \mathbf{\Lambda}^*]) = 0$ , and hence

$$\text{Tr}(d\mathbf{Z} d\mathbf{Z}^*) = \text{Tr}(d\mathbf{\Lambda} d\mathbf{\Lambda}^*) + \text{Tr} ([d\mathbf{S}, \mathbf{\Lambda}] [d\mathbf{S}, \mathbf{\Lambda}^*]). \quad (\text{A.3})$$

Setting  $d\mathbf{S} = [ds_{m,n}]_{m,n=1}^N$  and  $\mathbf{\Lambda} = [\delta_{m,n} \lambda_m]_{m,n=1}^N$ , then

$$[d\mathbf{S}, \mathbf{\Lambda}] = [ds_{m,n}(\lambda_n - \lambda_m)]_{m,n=1}^N \quad \text{and} \quad [d\mathbf{S}, \mathbf{\Lambda}^*] = [ds_{m,n}(\bar{\lambda}_n - \bar{\lambda}_m)]_{m,n=1}^N,$$

and

$$\begin{aligned} \text{Tr}([d\mathbf{S}, \mathbf{\Lambda}][d\mathbf{S}, \mathbf{\Lambda}^*]) &= \sum_{m=1}^N \sum_{n=1}^N ds_{m,n}(\lambda_n - \lambda_m) ds_{n,m}(\bar{\lambda}_m - \bar{\lambda}_n) \\ &= - \sum_{m<n} ds_{m,n} ds_{n,m} |\bar{\lambda}_m - \bar{\lambda}_n|^2 - \sum_{m>n} ds_{m,n} ds_{n,m} |\bar{\lambda}_m - \bar{\lambda}_n|^2. \end{aligned}$$

Using the fact that  $d\mathbf{S}$  is antihermitian, that is  $ds_{n,m} = -\bar{d}s_{m,n}$ , we find

$$\text{Tr}([d\mathbf{S}, \mathbf{\Lambda}][d\mathbf{S}, \mathbf{\Lambda}^*]) = 2 \sum_{m<n} |ds_{m,n}|^2 |\bar{\lambda}_m - \bar{\lambda}_n|^2,$$

and hence, by (A.3),

$$\text{Tr}(d\mathbf{Z}d\mathbf{Z}^*) = \sum_{n=1}^N |d\lambda_n|^2 + 2 \sum_{m<n} |ds_{m,n}|^2 |\lambda_m - \lambda_n|^2.$$

Finally, we define the vector of ‘spectral variables’

$$d\mathbf{v} = (d\lambda_1, \dots, d\lambda_N, ds_{1,2}, \dots, ds_{1,N}, ds_{2,3}, \dots, ds_{2,N}, \dots, ds_{N-1,N})$$

and thus,

$$\text{Tr}(d\mathbf{Z}d\mathbf{Z}^*) = d\bar{\mathbf{v}}^T \mathbf{G} d\mathbf{v},$$

where  $\mathbf{G}$  is the Hermitian metric tensor

$$\left[ \begin{array}{cccccccc} \mathbf{I} & & & & & & & \\ & 2|\lambda_1 - \lambda_2|^2 & & & & & & \\ & & \ddots & & & & & \\ & & & 2|\lambda_1 - \lambda_N|^2 & & & & \\ & & & & 2|\lambda_2 - \lambda_3|^2 & & & \\ & & & & & \ddots & & \\ & & & & & & 2|\lambda_2 - \lambda_N|^2 & \\ & & & & & & & \ddots \\ & & & & & & & & 2|\lambda_{N-1} - \lambda_N|^2 \end{array} \right]$$

and  $\mathbf{I}$  is the  $N \times N$  identity matrix. The metric tensor induces a volume form on  $\mathcal{N}_N(\mathbb{C})$  as parametrized by the spectral variables as given by

$$d\omega = |\det \mathbf{G}| \left\{ \bigwedge_{n=1}^N d\lambda_n \right\} \wedge \left\{ \bigwedge_{m<n} ds_{m,n} \right\},$$

and it is easily seen that

$$\det \mathbf{G} = 2^{N(N-1)/2} \left\{ \prod_{m<n} |\lambda_m - \lambda_n|^2 \right\}.$$

Integrating out the spectral variables which correspond to the entries of  $d\mathbf{S}$ —and therefore only on the eigenvectors of  $\mathbf{Z}$ —we are left with a form dependent only on the eigenvalues.

That is, there exists a constant  $C_N$ , depending only on  $N$ , so that the induced volume form on eigenvalues is given by

$$d\omega_{\text{eigs}} = C_N \left\{ \prod_{m < n} |\lambda_m - \lambda_n|^2 \right\} d\lambda_1 \wedge \cdots \wedge d\lambda_N. \quad (\text{A.4})$$

### A.1.2 Real Normal Matrices

Here we fix  $L$  and  $M$  so that  $L + 2M = N$  and we suppose that  $\mathbf{X}$ ,  $\mathbf{O}$  and  $\mathbf{\Gamma}$  are given as in (A.2). Next we set  $\beta_m = x_m + iy_m$ ;  $m = 1, 2, \dots, M$  and define the  $N \times N$  matrices

$$\mathbf{\Lambda} = \begin{bmatrix} \alpha_1 & & & & & & & & & & \\ & \ddots & & & & & & & & & \\ & & \alpha_L & & & & & & & & \\ & & & \beta_1 & & & & & & & \\ & & & & \bar{\beta}_1 & & & & & & \\ & & & & & \ddots & & & & & \\ & & & & & & \beta_M & & & & \\ & & & & & & & & \bar{\beta}_M & & \end{bmatrix},$$

and

$$\mathbf{Y} = \begin{bmatrix} 1 & & & & & & & & & & \\ & \ddots & & & & & & & & & \\ & & 1 & & & & & & & & \\ & & & \mathbf{C} & & & & & & & \\ & & & & \ddots & & & & & & \\ & & & & & & \mathbf{C} & & & & \end{bmatrix} \quad \text{where} \quad \mathbf{C} = \frac{1}{\sqrt{2}} \begin{bmatrix} 1 & -i \\ -i & 1 \end{bmatrix};$$

the upper left block of  $\mathbf{Y}$  is the  $L \times L$  identity matrix, where the lower right block is block diagonal consisting of  $M$  non-zero blocks. It is easily seen that  $\mathbf{Y}$  is unitary, and  $\mathbf{Y}\mathbf{\Gamma}\mathbf{Y}^* = \mathbf{\Lambda}$ . That is, if we define  $\mathbf{U} = \mathbf{O}\mathbf{Y}$ ,

$$\mathbf{X} = \mathbf{U}\mathbf{\Lambda}\mathbf{U}^*.$$

It follows from arguments in Section A.1.1 that

$$\begin{aligned} \text{Tr}(d\mathbf{X} d\mathbf{X}^*) &= \sum_{\ell=1}^L d\alpha_{\ell}^2 + 2 \sum_{m=1}^M |d\beta_m|^2 + 2 \sum_{j < k}^L |ds_{j,k}|^2 |\alpha_j - \alpha_k|^2 \\ &\quad + 2 \sum_{\ell=1}^L \sum_{m=1}^M ds_{\ell, L+2m-1} |\alpha_{\ell} - \beta_m|^2 + ds_{\ell, L+2m} |\alpha_{\ell} - \bar{\beta}_m|^2 \\ &\quad + 2 \sum_{m < n}^M ds_{L+2m-1, L+2n-1} |\beta_m - \beta_n|^2 + ds_{L+2m-1, L+2n} |\beta_m - \bar{\beta}_n|^2 \\ &\quad + 2 \sum_{m < n}^M ds_{L+2m, L+2n} |\bar{\beta}_m - \bar{\beta}_n|^2 + ds_{L+2m, L+2n-1} |\bar{\beta}_m - \beta_n|^2 \\ &\quad + 2 \sum_{m=1}^M |\beta_m - \bar{\beta}_m|^2. \end{aligned}$$

We observe that,

$$d\mathbf{S} = \mathbf{U} d\mathbf{U}^* = \mathbf{O}\mathbf{Y} d(\mathbf{O}\mathbf{Y})^* = \mathbf{O}\mathbf{Y}\mathbf{Y}^* d\mathbf{O}^\top = \mathbf{O} d\mathbf{O}^\top,$$

and consequently  $d\mathbf{S}$  is independent of  $\mathbf{Y}$ . We also note that  $|d\beta_m|^2 = dx_m^2 + dy_m^2$ .

Like in the case of complex normal matrices, we introduce spectral variables

$$d\alpha_1, \dots, d\alpha_L, dx_1, dy_1, \dots, dx_M, dy_M, ds_{1,2}, \dots, ds_{1,N}, ds_{2,3}, \dots, ds_{2,N}, \dots, ds_{N-1,N}.$$

It is easy to compute the Riemannian metric with respect to these variables, and the volume form on  $\mathcal{N}_N(\mathbb{R})$  is given by

$$\omega = \sqrt{|\det \mathbf{G}|} \left\{ \bigwedge_{\ell=1}^L d\alpha_\ell \right\} \wedge \left\{ \bigwedge_{m=1}^M dx_m \wedge dy_m \right\} \wedge \left\{ \bigwedge_{m<n} ds_{m,n} \right\},$$

where

$$\begin{aligned} |\det \mathbf{G}| = & 2^{N(N-1)/4} 2^M \left\{ \prod_{j<k}^L |\alpha_j - \alpha_k| \right\} \left\{ \prod_{\ell=1}^L \prod_{m=1}^M |\alpha_\ell - \beta_m|^2 \right\} \\ & \times \left\{ \prod_{m<n}^M |\beta_m - \beta_n|^2 \right\} \left\{ \prod_{m=1}^M 2|\operatorname{Im}(\beta_m)| \right\}. \end{aligned}$$

We conclude by integrating over the entries of  $d\mathbf{S}$  that there is a constant  $c_N$  depending only on  $N$ , such that the induced volume form in eigenvalues is given by

$$\begin{aligned} \omega_{\text{eigs}} = & c_N 2^M \left\{ \prod_{j<k}^L |\alpha_j - \alpha_k| \right\} \left\{ \prod_{\ell=1}^L \prod_{m=1}^M |\alpha_\ell - \beta_m|^2 \right\} \\ & \times \left\{ \prod_{m<n}^M |\beta_m - \beta_n|^2 \right\} \left\{ \prod_{m=1}^M 2|\operatorname{Im}(\beta_m)| \right\} \left\{ \bigwedge_{\ell=1}^L d\alpha_\ell \right\} \wedge \left\{ \bigwedge_{m=1}^M dx_m \wedge dy_m \right\}. \end{aligned} \quad (\text{A.5})$$

## A.2 The Induced Measure on Eigenvalues

Given  $\boldsymbol{\lambda} \in \mathbb{C}^N$ , we define the Vandermonde matrix and determinant by

$$\Delta(\boldsymbol{\lambda}) = \det \mathbf{V}(\boldsymbol{\lambda}) \quad \text{where} \quad \mathbf{V}(\boldsymbol{\lambda}) = [\lambda_n^{m-1}]_{m,n=1}^N.$$

More generally, given a family of monic polynomials  $\mathbf{p} = (p_1, p_2, \dots, p_N)$  with  $\deg p_n = n-1$  we define the Vandermonde matrix for the family  $\mathbf{p}$  by

$$\mathbf{V}^{\mathbf{p}}(\boldsymbol{\lambda}) = [p_m(\lambda_n)]_{m,n=1}^N.$$

We will call such a family of polynomials a *complete* set of monic polynomials. It is easily seen that

$$\det \mathbf{V}^{\mathbf{p}}(\boldsymbol{\lambda}) = \det \mathbf{V}(\boldsymbol{\lambda}) = \prod_{m<n} (\lambda_n - \lambda_m) = \Delta(\boldsymbol{\lambda}).$$

It follows that, in the case of  $\mathcal{N}_N(\mathbb{C})$ , the measure on eigenvalues  $\xi_N$  induced by (A.4) is given by

$$d\xi_N(\boldsymbol{\lambda}) = C_N |\Delta(\boldsymbol{\lambda})|^2 d\mu_{\mathbb{C}}^N(\boldsymbol{\lambda}),$$

where  $\mu_{\mathbb{C}}^N$  is Lebesgue measure on  $\mathbb{C}^N$ .

Similarly, for  $\mathcal{N}_N(\mathbb{R})$ , and the sector of eigenvalues represented by  $\mathbb{R}^L \times \mathbb{C}^M$ : Given  $\boldsymbol{\beta} = (\beta_1, \dots, \beta_M) \in \mathbb{C}^M$  and  $\boldsymbol{\alpha} = (\alpha_1, \dots, \alpha_L) \in \mathbb{R}^L$  then the measure on eigenvalues  $\xi_{L,M}$  induced by (A.5) is given by

$$d\xi_{L,M}(\boldsymbol{\alpha}, \boldsymbol{\beta}) = c_N 2^M |\Delta(\boldsymbol{\alpha}, \boldsymbol{\beta})| d\mu_{\mathbb{R}}^L(\boldsymbol{\alpha}) d\mu_{\mathbb{C}}^M(\boldsymbol{\beta}),$$

where  $\Delta(\boldsymbol{\alpha}, \boldsymbol{\beta})$  is the Vandermonde determinant in the variables  $\alpha_1, \dots, \alpha_L, \beta_1, \bar{\beta}_1, \dots, \beta_M, \bar{\beta}_M$ .

## References

- [1] G. Akemann, J. Baik, and P. Di Francesco. *The Oxford handbook of random matrix theory*. Oxford University Press, Oxford, 2011. 5
- [2] Yuri Bilu. Limit distribution of small points on algebraic tori. *Duke Math. J.*, 89(3):465–476, 1997. 4
- [3] A. Bloch and G. Pólya. On the Roots of Certain Algebraic Equations. *Proc. London Math. Soc.*, S2-33(1):102. 2
- [4] Alexei Borodin and Christopher D. Sinclair. Correlation functions of ensembles of asymmetric real matrices, 2007. Accepted for publication in *Comm. Math. Phys.* 11, 12
- [5] Alexei Borodin and Christopher D. Sinclair. The Ginibre ensemble of real random matrices and its scaling limits. *Comm. Math. Phys.*, 291(1):177–224, 2009. 11, 12
- [6] Shey-Jey Chern and Jeffrey D. Vaaler. The distribution of values of Mahler’s measure. *J. Reine Angew. Math.*, 540:1–47, 2001. 6, 9
- [7] Amir Dembo, Bjorn Poonen, Qi-Man Shao, and Ofer Zeitouni. Random polynomials having few or no real zeros. *J. Amer. Math. Soc.*, 15(4):857–892 (electronic), 2002. 3
- [8] Freeman J. Dyson. Statistical theory of the energy levels of complex systems. III. *J. Mathematical Phys.*, 3:166–175, 1962. 5
- [9] Freeman J. Dyson. Correlations between eigenvalues of a random matrix. *Comm. Math. Phys.*, 19:235–250, 1970. 5
- [10] Alan Edelman, Eric Kostlan, and Michael Shub. How many eigenvalues of a random matrix are real? *J. Amer. Math. Soc.*, 7(1):247–267, 1994. 3
- [11] P. Erdős and P. Turán. On the distribution of roots of polynomials. *Ann. of Math. (2)*, 51:105–119, 1950. 3
- [12] Paul Erdős and A. C. Offord. On the number of real roots of a random algebraic equation. *Proc. London Math. Soc. (3)*, 6:139–160, 1956. 3
- [13] F.W.J Olver et al., editor. *NIST handbook of mathematical functions*. Cambridge University Press, Cambridge, 2010. 29, 38, 39, 47
- [14] Peter Forrester and Anthony Mays. A method to calculate correlation functions for  $\beta = 1$  random matrices of odd size. *J. Statist. Phys.*, 134(3):443–462, 2009. 26

- [15] Michel Gaudin. Sur la loi limite de l'espacement des valeurs propres d'une matrice aléatoire. *Nuclear Physics*, 25(0):447 – 458, 1961. [5](#)
- [16] J. M. Hammersley. The zeros of a random polynomial. In *Proceedings of the Third Berkeley Symposium on Mathematical Statistics and Probability, 1954–1955, vol. II*, pages 89–111, Berkeley and Los Angeles, 1956. University of California Press. [3](#)
- [17] J. Ben Hough, Manjunath Krishnapur, Yuval Peres, and Bálint Virág. *Zeros of Gaussian analytic functions and determinantal point processes*, volume 51 of *University Lecture Series*. American Mathematical Society, Providence, RI, 2009. [11](#)
- [18] Ildar Ibragimov and Ofer Zeitouni. On roots of random polynomials. *Trans. Amer. Math. Soc.*, 349(6):2427–2441, 1997. [3](#)
- [19] M. Kac. On the average number of real roots of a random algebraic equation. *Bull. Amer. Math. Soc.*, 49:314–320, 1943. [3](#), [11](#), [17](#)
- [20] M. Kac. On the average number of real roots of a random algebraic equation. II. *Proc. London Math. Soc. (2)*, 50:390–408, 1949. [3](#)
- [21] L. Kronecker. Zwei sätze über gleichungen mit ganzzahligen coefficienten. *Journal für die reine und angewandte Mathematik*, 53:173–175, 1857. [4](#)
- [22] A. B. J. Kuijlaars. Universality. In *The Oxford handbook of random matrix theory*, pages 103–134. Oxford Univ. Press, Oxford, 2011. [5](#)
- [23] D. H. Lehmer. Factorization of certain cyclotomic functions. *Ann. of Math. (2)*, 34(3):461–479, 1933. [4](#)
- [24] J. E. Littlewood and A. C. Offord. On the Number of Real Roots of a Random Algebraic Equation. *J. London Math. Soc.*, S1-13(4):288. [2](#)
- [25] J. E. Littlewood and A. C. Offord. On the number of real roots of a random algebraic equation. ii. *Mathematical Proceedings of the Cambridge Philosophical Society*, 35:133–148, 3 1939. [2](#)
- [26] D.S. Lubinsky. Universality limits for random matrices and de Branges spaces of entire functions. *J. Funct. Anal.*, 256:3688—3729, 2009. [5](#)
- [27] D.S. Lubinsky. Bulk universality holds in measure for compactly supported measures. *J. Analyse Mathématique*, 116:219—253, 2012. [5](#)
- [28] M. L. Mehta. On the statistical properties of the level-spacings in nuclear spectra. *Nuclear Phys.*, 18:395–419, 1960. [5](#)
- [29] M. L. Mehta. A note on correlations between eigenvalues of a random matrix. *Comm. Math. Phys.*, 20:245–250, 1971. [5](#)
- [30] M. L. Mehta and M. Gaudin. On the density of eigenvalues of a random matrix. *Nuclear Phys.*, 18:420–427, 1960. [5](#)
- [31] Madan Lal Mehta. *Random matrices*, volume 142 of *Pure and Applied Mathematics (Amsterdam)*. Elsevier/Academic Press, Amsterdam, third edition, 2004. [12](#)

- [32] Thomas Ransford. *Potential theory in the complex plane*, volume 28 of *London Mathematical Society Student Texts*. Cambridge University Press, Cambridge, 1995. 23
- [33] Larry A. Shepp and Robert J. Vanderbei. The complex zeros of random polynomials. *Trans. Amer. Math. Soc.*, 347(11):4365–4384, 1995. 3, 11
- [34] Christopher D Sinclair. Averages over Ginibre’s ensemble of random real matrices. *Int. Math. Res. Not.*, 2007:1–15, 2007. 6
- [35] Christopher D. Sinclair. The range of multiplicative functions on  $\mathbb{C}[x]$ ,  $\mathbb{R}[x]$  and  $\mathbb{Z}[x]$ . *Proc. London Math. Soc.*, 96(3):697–737, 2008. 6, 9, 10, 25
- [36] Christopher D. Sinclair. Correlation functions for  $\beta=1$  ensembles of matrices of odd size. *J. Stat. Phys.*, 136(1):17–33, 2009. 26
- [37] Christopher D. Sinclair and Maxim L. Yattselev. Universality for ensembles of matrices with potential theoretic weights on domains with smooth boundary. *Journal of Approximation Theory*, 164(5):682 – 708, 2012. 16
- [38] Peter Walters. *An introduction to ergodic theory*, volume 79 of *Graduate Texts in Mathematics*. Springer-Verlag, New York, 1982. 24
- [39] M. Yattselev. Large deviations and linear statistics for potential theoretic ensembles associated with regular closed sets. *Probab. Theory Relat. Fields.*, 165(827—850), 2013. 15
- [40] S. Yuzvinski. Metric properties of endomorphisms of compact groups. *Izv. Acad. Nauk SSSR, Ser. Mat.*, 29:1295–1328, 1965. 24

---

CHRISTOPHER D. SINCLAIR

Department of Mathematics, University of Oregon, Eugene OR 97403  
email: [csinclai@uoregon.edu](mailto:csinclai@uoregon.edu)

MAXIM L. YATTSELEV

Department of Mathematical Sciences, Indiana University — Purdue University Indianapolis,  
402 North Blackford Street, Indianapolis, IN 46202  
email: [maxyatts@math.iupui.edu](mailto:maxyatts@math.iupui.edu)